

## BIDI-XFP-LR-33

6COM, BIDI XFP,10Gbps ,1330nm,SMF,10KM, DDM,LC connector, 0°C ~ +70°C

### PRODUCT FEATURES

- ◆ Up to 10.7Gbps Data Links
- ◆ Single Mode LC Receptacle Bi-directional Transceiver
- ◆ Up to 10km transmission on SMF
- ◆ Power dissipation<1.5W
- ◆ 1330nm DFB laser and PIN receiver
- ◆ 2-wire interface with integrated Digital Diagnostic monitoring
- ◆ EEPROM with Serial ID Functionality
- ◆ Compliant with FC\_PI\_4 REV 7.0
- ◆ Compliant with XFP MSA with duplex LC connector
- ◆ Single + 3.3V Power Supply and LVTTTL Logic
- ◆ Operating case temperature: 0~+70°C



### APPLICATIONS

- ◆ 10GBASE-BX 10.3125Gb/s Ethernet
- ◆ 10GBASE-BX 9.953Gb/s Ethernet
- ◆ SONET OC-192 SR-1 SDH STM I-64.1

### 1. Description

BIDI-XFP-LR-33 is hot pluggable 3.3V Small-Form-Factor transceiver module. It designed expressly for high-speed communication applications that require rates up to 10.7 Gb/s, it designed to be compliant with XFP MSA. The module data link up to 10km in 9/125um single mode fiber.

The optical output can be disabled by a LVTTTL logic high-level input of Tx Disable. Tx Fault is provided to indicate that degradation of the laser. Loss of signal (LOS) output is provided to indicate the loss of an input optical signal of receiver or the link status with partner.

## 2. Absolute Maximum Ratings

Parameter	Symbol	Min.	Typ.	Max.	Unit	Note
Storage Temperature	Ts	-40	-	85	°C	
Storage Ambient Humidity	HA	5	-	95	%	
Operating Relative Humidity	RH	-	-	85	%	
Power Supply Voltage	VCC	-0.3	-	4	V	
Signal Input Voltage	VCC	V <sub>cc</sub> -0.3	-	V <sub>cc</sub> +0.3	V	

## 3. Recommended Operating Conditions

Parameter	Symbol	Min.	Typ.	Max.	Unit	Note
Ambient Operating Temperature	TA	0	-	70	°C	Without air flow
Power Supply Voltage	VCC	3.14	3.3	3.47	V	
Power Supply Current	ICC	-	-	450	mA	
Data Rate	BR		10.3125		Gbps	
Transmission Distance	TD	2	-	20	km	Note (1)
Coupled fiber	Single mode fiber					ITU-T G.652

Note (1). Measured with SMF

## 4. Specification of Transmitter

Parameter	Symbol	Min.	Typ.	Max.	Unit	Note
Average Launched Power	PO	-5	-	0	dBm	
Average Launched Power(Laser Off)	POUT-OFF	-	-	-30	dBm	Note (1)
Optical Modulation Amplitude	OMA	-3	-	-	dBm	Note (1)
Center Wavelength Range	$\lambda$ C	1320	1330	1340	nm	
Side mode suppression ratio	SMSR	30	-	-	dB	
Spectrum Bandwidth(-20dB)	$\sigma$	-	-	1	nm	
Extinction Ratio	ER	3.5	6	-	dB	Note (2)
Output Eye Mask	Compliant with FC_PI_4 REV 7.0					Note (2)

Note (1).The optical power is launched into SMF

Note (2). Measured with RPBS 2^31-1 test pattern @10.3125Gbs

## 5. Specification of Receiver

Parameter	Symbol	Min.	Typ.	Max.	Unit	Note
Input Optical Wavelength	$\lambda_{IN}$	1260	1270	1280	nm	
Receiver Sensitivity	PIN	-	-	-14.4	dBm	Note (1)
Input Saturation Power (Overload)	PSAT	0.5	-	-	dBm	Note (1)
LOS -Assert Power	PA	-30	-	-	dBm	
LOS -Deassert Power	PD	-	-	-18	dBm	
LOS -Hysteresis	PHys	0.5	-	4	dB	

Note (1). Measured with RPBS 2^31-1 test pattern @10.3125Gbs BER= $\leq 10^{-12}$  ER=6DB

## 6. Electrical Interface Characteristics

Parameter	Symbol	Min.	Typ.	Max.	Unit	Note
Total power supply current	Icc	-	-	350	mA	
<b>Transmitter</b>						
Differential Data Input Voltage	VDT	120	-	820	mVp-p	
Differential line input Impedance	RIN	85	100	115	Ohm	
Transmitter Fault Output-High	VFaultH	2.4	-	Vcc	V	
Transmitter Fault Output-Low	VFaultL	-0.3	-	0.8	V	
Transmitter Disable Voltage-High	VDisH	2	-	Vcc+0.3	V	
Transmitter Disable Voltage- low	VDisL	-0.3	-	0.8	V	
<b>Receiver</b>						
Differential Data Output Voltage	VDR	300	-	850	mVp-p	
Differential line Output Impedance	ROUT	80	100	120	Ohm	
Receiver LOS Pull up Resistor	RLOS	4.7	-	10	KOhm	
Data Output Rise/Fall time	tr/tf	20	-	-	ps	
LOS Output Voltage-High	VLOSH	2	-	Vcc	V	
LOS Output Voltage-Low	VLOSL	-0.3	-	0.4	V	

## 7.Pin Description

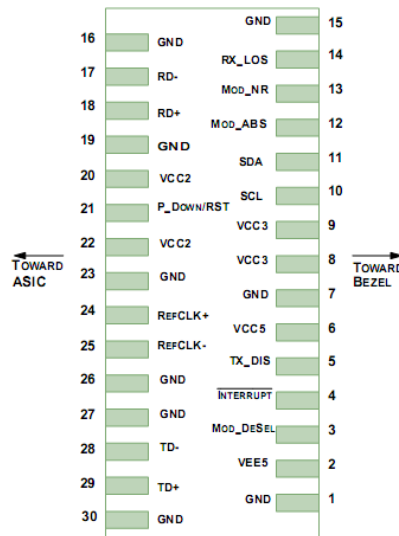

Pin	Logic	Symbol	Name/Description	Note
1		GND	Module Ground	1
2		VEE5	Optional -5.2 Power Supply – <b>Not required</b>	
3	LVTTL-I	Mod-Desel	Module De-select; When held low allows the module to respond to 2-wire serial interface commands	
4	LVTTL-O	Interrupt	Interrupt (bar); Indicates presence of an important condition which can be read over the serial 2-wire interface	2
5	LVTTL-I	TX_DIS	Transmitter Disable; Transmitter laser source turned off	
6		VCC5	+5 Power Supply	
7		GND	Module Ground	1
8		VCC3	+3.3V Power Supply	
9		VCC3	+3.3V Power Supply	
10	LVTTL-I	SCL	Serial 2-wire interface clock	2
11	LVTTLI/O	SDA	Serial 2-wire interface data line	2
12	LVTTL-O	Mod_Abs	Module Absent; Indicates module is not present. Grounded in the module.	2
13	LVTTL-O	Mod_NR	Module Not Ready; XGIGA defines it as a logical OR between RX_LOS and Loss of Lock in TX/RX.	2
14	LVTTL-O	RX_LOS	Receiver Loss of Signal indicator	2
15		GND	Module Ground	1
16		GND	Module Ground	1
17	CML-O	RD-	Receiver inverted data output	
18	CML-O	RD+	Receiver non-inverted data output	
19		GND	Module Ground	1
20		VCC2	+1.8V Power Supply – <b>Not required</b>	
21	LVTTL-I	P_Down/RST	Power Down; When high, places the module	

			in the low power stand-by mode and on the falling edge of P_Down initiates a module reset	
			Reset; The falling edge initiates a complete reset of the module including the 2-wire serial interface, equivalent to a power cycle.	
22		VCC2	+1.8V Power Supply – <b>Not required</b>	
23		GND	Module Ground	1
24	PECL-I	RefCLK+	Reference Clock non-inverted input, AC coupled on the host board – <b>Not required</b>	3
25	PECL-I	RefCLK-	Reference Clock inverted input, AC coupled on the host board – <b>Not required</b>	3
26		GND	Module Ground	1
27		GND	Module Ground	1
28	CML-I	TD-	Transmitter inverted data input	
29	CML-I	TD+	Transmitter non-inverted data input	
30		GND	Module Ground	1

**Notes:**

1. Module circuit ground is isolated from module chassis ground within the module.
2. Open collector; should be pulled up with 4.7k – 10kohms on host board to a voltage between 3.15V and 3.6V.
3. A Reference Clock input is not required by the XFP-10GLR. If present, it will be ignored.

## 8.Recommended Block Circuit

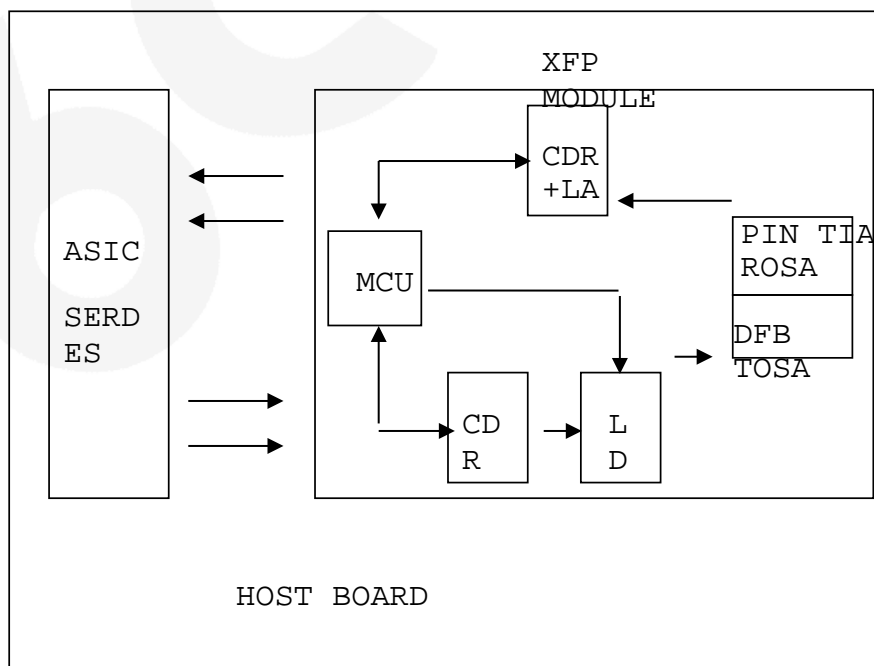

## 9. Outline Dimensions

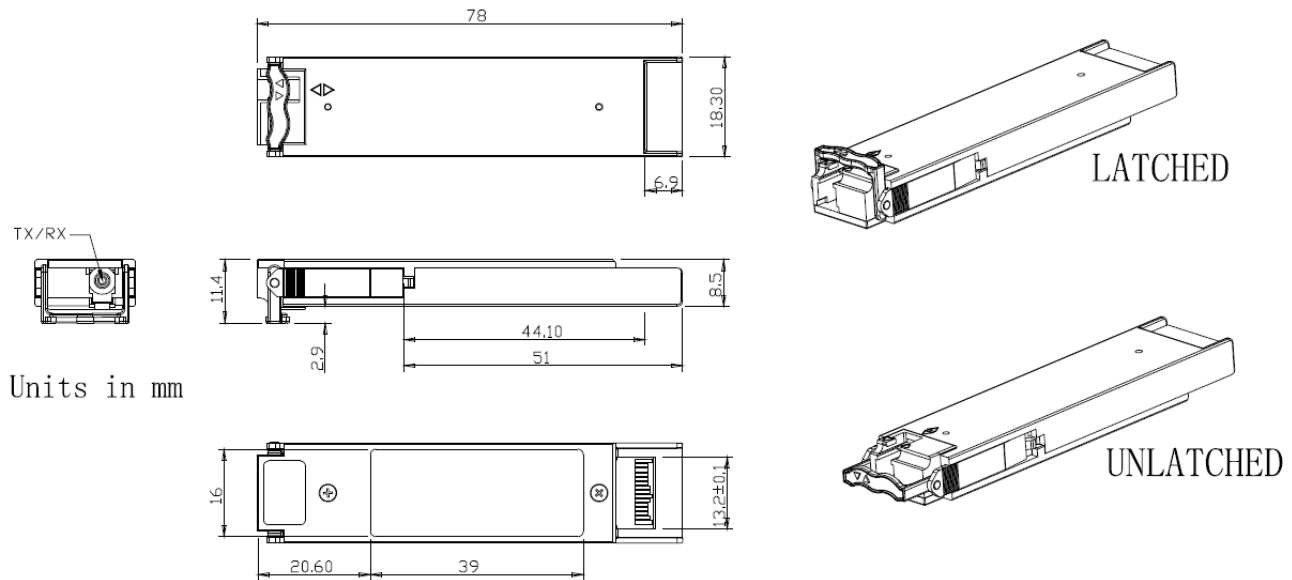

## 10. Ordering information

Part Number	Product Description
BIDI-XFP-LR-33	BIDI XFP,10Gbps ,1330nm,SMF,10KM, DDM,LC connector, 0°C ~ +70°C