

6C-XFP-LR

6COM, XFP,10Gbps ,1310nm,SMF,10KM, DDM,LC connector, 0°C ~ +70°C

FEATURES

- ◆ Supports 9.95Gb/s to 11.1Gb/s bit rates
- ◆ Hot-pluggable XFP footprint
- ◆ Maximum link length of 10km with SMF
- ◆ 1310nm Uncooled EML laser and PIN photodiode
- ◆ XFP MSA package with duplex LC connector
- ◆ No reference clock required
- ◆ +5V, +3.3V power supply
- ◆ Power dissipation <2.5W
- ◆ Compatible with RoHS
- ◆ Built-in digital diagnostic functions
- ◆ Temperature range 0°C to 70°C



APPLICATIONS

- ◆ SDH STM I-64.1 at 9.953Gbps
- ◆ 10GBASE-LR/LW 10G Ethernet
- ◆ 1200-SM-LL-L 10G Fibre Channel
- ◆ 10GE over G.709 at 11.09Gbps
- ◆ OC192 over FEC at 10.709Gbps
- ◆ Other optical links, up to 11.1Gbps

DESCRIPTION

6COM 6C-XFP-LR is compliant with the 10G Small Form-Factor Pluggable (XFP) Multi-Source Agreement (MSA), supporting data-rate of 10.3125Gbps(10GBASE-LR) or 9.953Gbps 10GBASE-LW), and transmission distance up to 10km on SMF.

The transceiver module comprises a transmitter with 1310nm uncooled EML laser and a receiver with a PIN photodiode. Transmitter and receiver are separate within a wide temperature range of 0°C to +70°C and offers optimum heat dissipation and excellent electromagnetic shielding thus enabling high port densities for 10 GbE systems.

1. Absolute Maximum Ratings

Parameter	Symbol	Min	Max	Unit	Ref.
Storage Ambient Temperature Range		-40	+85	°C	
Powered case Temperature Range		0	+75	°C	
Operating Relative Humidity	RH		80	%	
Supply Voltage Range @5V	Vcc5	-0.5	6.0	V	
Supply Voltage Range @ 3.3V	Vcc3	-0.5	4.0	V	

Any stress beyond the maximum ratings can result in permanent damage. The device specifications are guaranteed only under the recommended operating conditions.

2. Electrical Characteristics

Parameter	Symbol	Min	Typ	Max	Unit	Note	
Operating Case Temperature Range	T_c	0		+70	°C		
Power Supply Voltage @ 5V	Vcc5	4.75	5.0	5.25	V		
Power Supply Voltage @ 3.3V	Vcc3	3.13	3.3	3.47	V		
Module total power	P			2.5	W		
Transmitter							
Input differential impedance	Rin		100		Ω	1	
Differential data input swing	V _{in,pp}	120		820	mV		
Transmit Disable Voltage	VD	2.0		V _{cc}	V		
Transmit Enable Voltage	VEN	GND		GND+ 0.8	V		
Transmit Disable Assert Time				10	us		
Receiver							
Differential data output swing	V _{out,pp}	500		850	mV		
Data output rise time	t _r			38	ps	2	
Data output fall time	t _f			38	ps	2	
LOS Fault	V _{LOS fault}	V _{cc} – 0.5		V _{CCHOST}	V	3	
LOS Normal	V _{LOS norm}	GND		GND+0.5	V	3	
Power Supply Rejection	PSR	See Note 3 below					4

Notes:

1. After internal AC coupling.
2. 20 – 80 %
3. Loss of Signal is open collector to be pulled up with a 4.7k – 10kohm resistor to 3.15 – 3.6V. Logic 0 indicates normal operation; logic 1 indicates no signal detected.
4. Per Section 2.7.1.in the XFP MSA Specification.

3. Optical Characteristics

Parameter	Symbol	Min	Typ	Max	Unit	Ref.
Transmitter						
Optical output Power	P	-6.5		+0.5	dBm	
Optical Wavelength	λ	1260		1355	nm	
Side Mode Suppression Ratio	SMSR	30			dB	
Optical Extinction Ratio	ER	6			dB	1
Average Launch power of OFF transmitter	POFF	-30			dBm	
Tx Jitter	Tx _j	Compliant with each standard requirements				
Receiver						
Receiver Sensitivity	RSENS		-16	-14.4	dBm	2
Receiver Sensitivity in OMA	RSENS			-12.5	dBm	2
Maximum Input Power	PMAX	+0.5			dBm	
Optical Center Wavelength	λ_C	1260		1600	nm	
LOS De-Assert	LOS _D			-15	dBm	
LOS Assert	LOS _A	-25			dBm	
LOS Hysteresis		1		4	dB	

Notes:

1. PRBS 2³¹-1 test pattern @10.3125Gbps.
2. PRBS 2³¹-1 test pattern @10.3125Gbps, BER≤10⁻¹².

4. Pin Descriptions

Pin	Logic	Symbol	Name/Description	Ref
1		GND	Module Ground	1
2		VEE5	Optional -5.2 Power Supply – Not required	
3	LVTTL-I	Mod-Desel	Module De-select; When held low allows the module to respond to 2-wire serial interface commands	
4	LVTTL-O	Interrupt	Interrupt (bar); Indicates presence of an important condition which can be read over the serial 2-wire interface	2
5	LVTTL-I	TX_DIS	Transmitter Disable; Transmitter laser source turned off	
6		VCC5	+5 Power Supply	

7		GND	Module Ground	1
8		VCC3	+3.3V Power Supply	
9		VCC3	+3.3V Power Supply	
10	LVTTTL-I	SCL	Serial 2-wire interface clock	2
11	LVTTTL-I/O	SDA	Serial 2-wire interface data line	2
12	LVTTTL-O	Mod_Abs	Module Absent; Indicates module is not present. Grounded in the module.	2
13	LVTTTL-O	Mod_NR	Module Not Ready;	2
14	LVTTTL-O	RX_LOS	Receiver Loss of Signal indicator	2
15		GND	Module Ground	1
16		GND	Module Ground	1
17	CML-O	RD-	Receiver inverted data output	
18	CML-O	RD+	Receiver non-inverted data output	
19		GND	Module Ground	1
20		VCC2	+1.8V Power Supply – Not required	
21	LVTTTL-I	P_Down/RST	Power Down; When high, places the module in the low power stand-by mode and on the falling edge of P_Down initiates a module reset	
			Reset; The falling edge initiates a complete reset of the module including the 2-wire serial interface, equivalent to a power cycle.	
22		VCC2	+1.8V Power Supply – Not required	
23		GND	Module Ground	1
24	PECL-I	RefCLK+	Reference Clock non-inverted input, AC coupled on the host board – Not required	3
25	PECL-I	RefCLK-	Reference Clock inverted input, AC coupled on the host board – Not required	3
26		GND	Module Ground	1
27		GND	Module Ground	1
28	CML-I	TD-	Transmitter inverted data input	
29	CML-I	TD+	Transmitter non-inverted data input	
30		GND	Module Ground	1

Notes:

1. Module circuit ground is isolated from module chassis ground within the module.
2. Open collector; should be pulled up with 4.7k – 10k ohms on host board to a voltage between

3.15V and 3.6V.

3. A Reference Clock input is not required.

5. Hostboard Connector Pinout

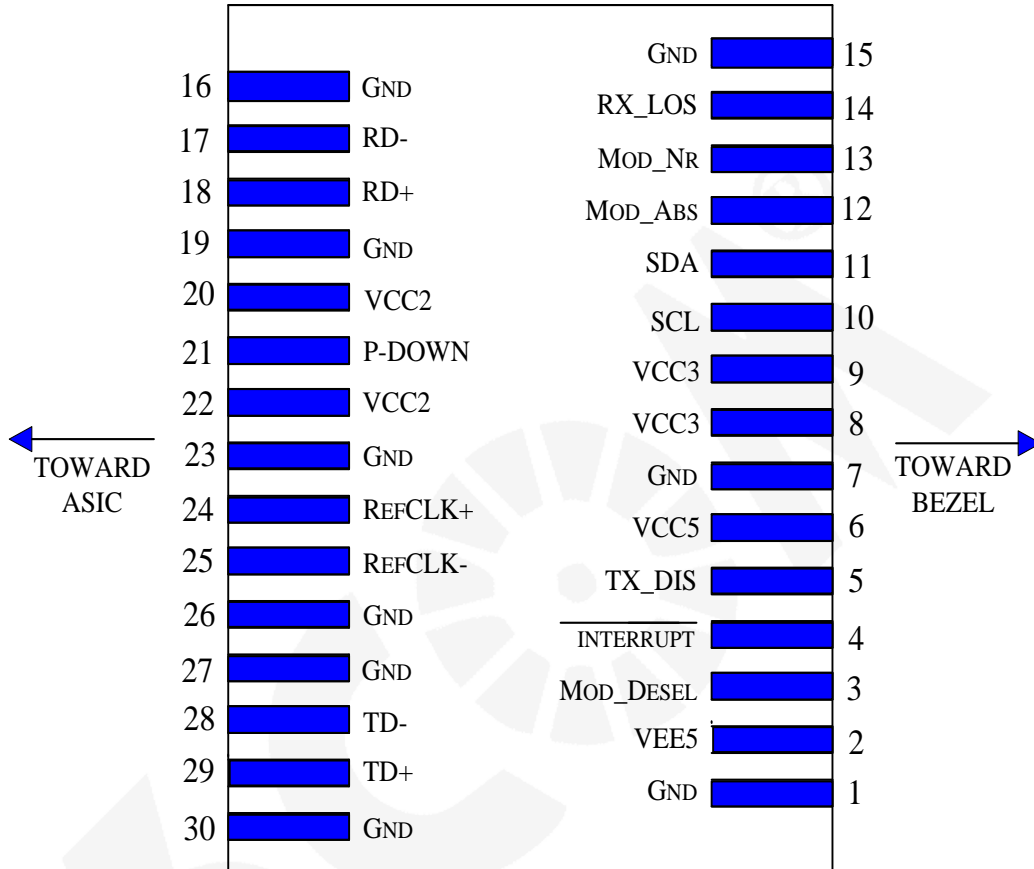

6. General Specifications

Parameter	Symbol	Min	Typ	Max	Units	Ref.
Bit Rate	BR	9.95		11.1	Gb/s	1
Bit Error Ratio	BER			10 ⁻¹²		2
Max. Supported Link Length	L _{MAX}		10		km	1

Notes:

1. SONET OC-192 SR-1, SDH STM I-64.1, 10GBASE-LR/LW, 1200-SM-LL-L
2. Tested with a 2³¹ - 1 PRBS

7. Management Interface

1. The transceivers provide serial ID memory contents and diagnostic information about the present operating conditions by the 2-wire serial interface (SCL, SDA).
2. The Module provides diagnostic information about the present operating conditions. The transceiver generates this diagnostic data by digitization of internal analog signals. Alarm/warning threshold data is written during device manufacture. Received power monitoring, transmitted power monitoring, bias current monitoring, supply voltage monitoring and temperature monitoring all are implemented.
3. The digital diagnostic memory map specific data field defines as following.

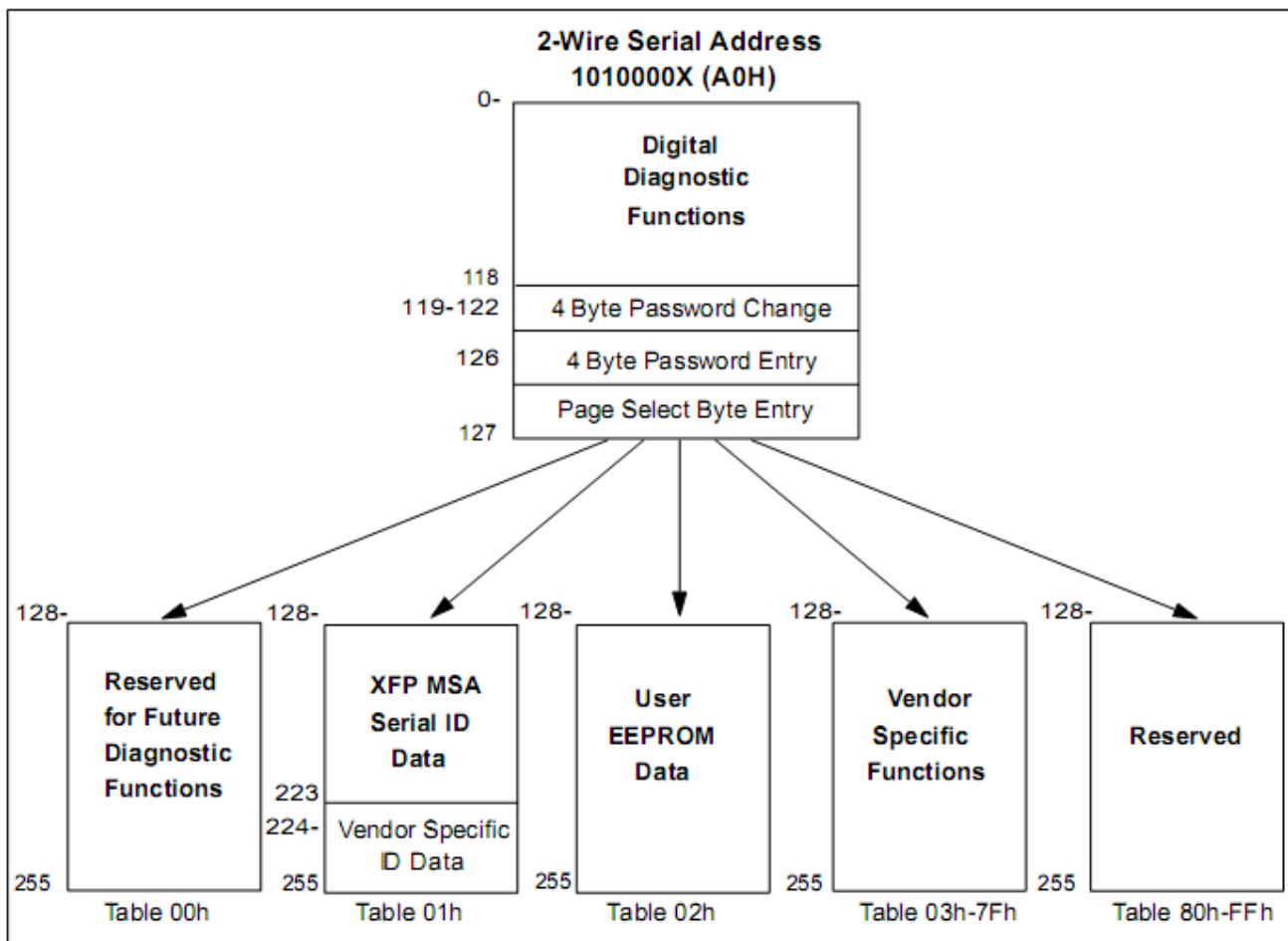

8. Recommended Host Board Power Supply Circuit

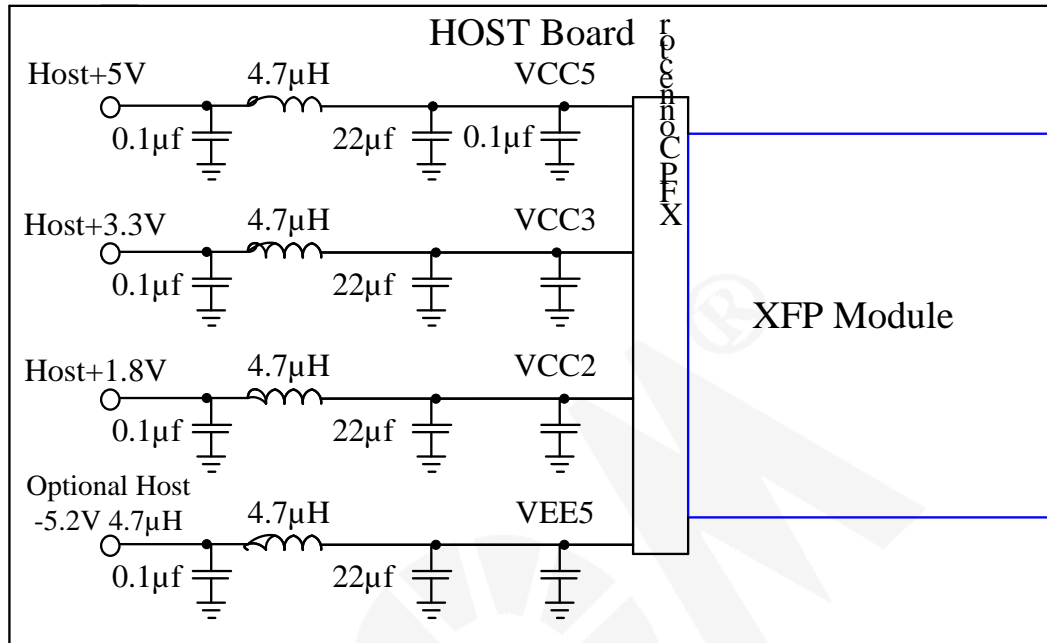

9. Recommended High-speed Interface Circuit

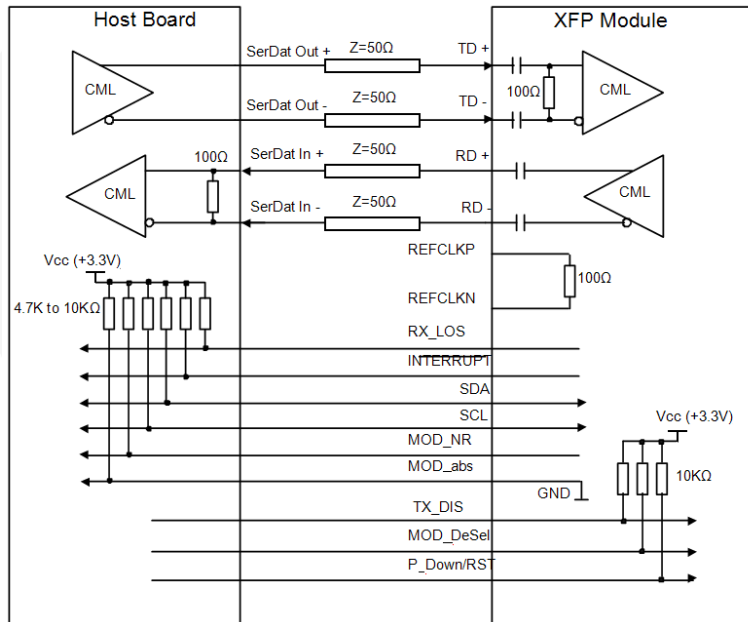

10. Mechanical Specifications

XFP transceivers are compliant with the dimensions defined by the XFP Multi-Sourcing Agreement (MSA).

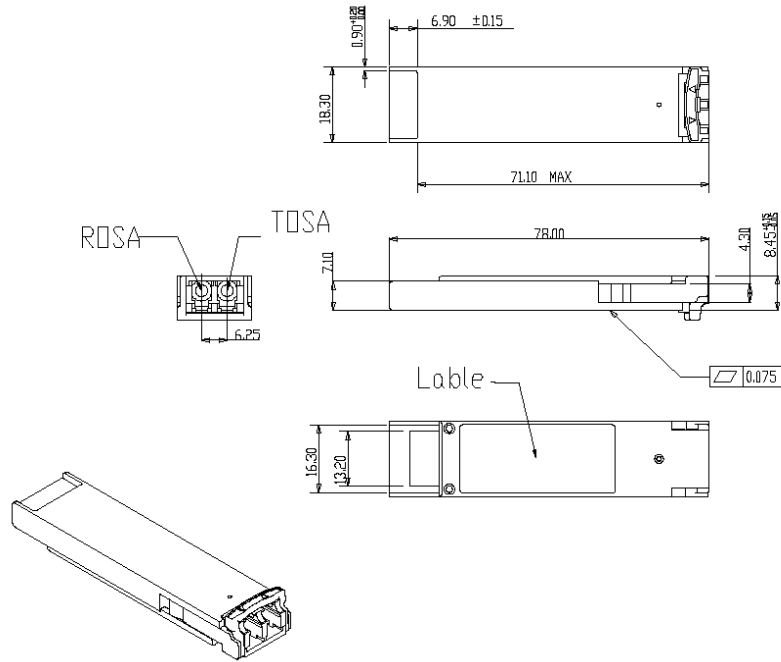

11. Ordering information

Part Number	Product Description
6C-XFP-LR	XFP,10Gbps ,1310nm,SMF,10KM, DDM,LC connector, 0°C ~ +70°C