

## CWDM-SFP+-ER-XX

6COM, SFP+,10Gbps ,1470~1610nm,SMF,40KM, DDM,LC connector, -5°C ~ +70°C

### PRODUCT FEATURES

- ◆ Compliant with SFF-8413 and IEE802.3ae
- ◆ Data rate selectable  $\leq 4.25$ Gbps or 9.95Gbps to 10.3Gbps bit rates
- ◆ Cooled EML transmitter and PIN receiver
- ◆ Wavelength selectable to ITU-T standards covering
- ◆ CWDM grid wavelengths
- ◆ link length up to 40km
- ◆ Low Power Dissipation 1.5W Maximum
- ◆ -5°C to 70°C Operating Case Temperature
- ◆ Single 3.3V power supply
- ◆ Diagnostic Performance Monitoring of module temperature, supply
- ◆ Voltages, laser bias current, transmit optical power, receive optical power
- ◆ RoHS compliant and lead free



### APPLICATIONS

- ◆ 10GBASE-ER/EW (with/without FEC)
- ◆ 10G Fiber Channel (with/without FEC)

### PRODUCT DESCRIPTION

6COM SFP+ER CWDM Transceiver is designed for 10GBASE-ER/EW, and 10G Fiber- Channel applications. The transceiver consists of two sections: The transmitter section incorporates a cooled EML laser. And the receiver section consists of a PIN photodiode integrated with a TIA. All modules satisfy class I laser safety requirements. Digital diagnostics functions are available via a 2-wire serial interface, as specified in SFF-8472, which allows real-time access to device operating parameters such as transceiver temperature, laser bias current, transmitted optical power, received optical power and transceiver supply voltage.

## 1. Absolute Maximum Ratings

Parameter	Symbol	Min	Max	Unit
Supply Voltage	Vcc	-0.5	3.8	V
Storage Temperature	Tst	-40	85	°C
Relative Humidity	Rh	0	85	%

## 2. Operating Conditions

Parameter	Symbol	Min	Typical	Max	Unit
Supply Voltage	Vcc	3.13	3.3	3.47	V
Supply current	Icc		360	450	mA
Operating Case temperature	Tca	-5	-	70	°C
Module Power Dissipation	Pm	-	1.2	1.5	W

### Notes:

[1] Supply current is shared between VCCTX and VCCR<sub>X</sub>.

[2] In-rush is defined as current level above steady state current requirements.

## 3. Transmitter Specifications - Optical

Parameter	Symbol	Min	Typical	Max	Unit
Center Wavelength	□c	□□□ □□□		□□□ □□□	nm
Center wavelength stability	□□D	□□□ □	□c	□□□	nm
Optical Average Power	Po	-2	-	+4	dBm
Optical OMA Power	Pom	-2.1			dBm
Side Mode Suppression Ratio	SMSR	30	-	-	dB
Optical Transmit Power (disabled)	PTX_DISABLE	-	-	-30	dBm
Extinction Ratio	ER	8.2		-	dB
RIN21OMA [1]				-128	dB/Hz
Optical Return Loss Tolerance				21	dB

### Notes:

[1] RIN measurement is made with a return loss at 21 dB.

#### 4. Transmitter Specifications – Electrical

Parameter	Symbol	Min	Typical	Max	Unit
Data Rate	Mra	-	10.3	11.3	Gbps
Input differential impedance	Rim	-	100	-	$\Omega$
Differential data Input	VtxDIFF	120	-	850	mV
Transmit Disable Voltage	VD	2.0	-	Vcc3+0.3	V
Transmit Enable Voltage	Ven	0	-	+0.8	V
Transmit Disable Assert Time	Vn	-	-	100	us

#### 5. Receiver Specifications – Optical

Parameter	Symbol	Min	Typical	Max	Unit
Input Operating Wavelength	$\lambda$	1260	-	1620	nm
Receiver sensitivity in OMA		-	-	-15.8	dBm
Maximum Input Power	RX-overload	-	-	-1	dBm
Reflectance	Rrx	-	-	-27	dB
Loss of Signal Asserted		-25	-	-	dBm
LOS De-Asserted		-	-	-16	dBm
LOS Hysteresis		0.5	-	-	dB

**Notes:**

[1] Measured with conformance test signal for BER = 10<sup>-12</sup>. The stressed sensitivity values in the table are for system level BER measurements which include the effects of CDR circuits. It is recommended that at least 0.4 dB additional margin be allocated if component level measurements are made without the effects of CDR circuits.

#### 6. Receiver Specifications – Electrical

Parameter	Symbol	Min	Typical	Max	Unit
Data Rate	Mra	-	10.3	11.3	Gbps
Differential Output Swing	Vout P-P	350	-	850	mV
Rise/Fall Time	Tr / Tf	24	-	-	ps
Loss of Signal –Asserted	VOH	2	-	Vcc3+0.3-	V
Loss of Signal –Negated	VOL	0	-	+0.4	V

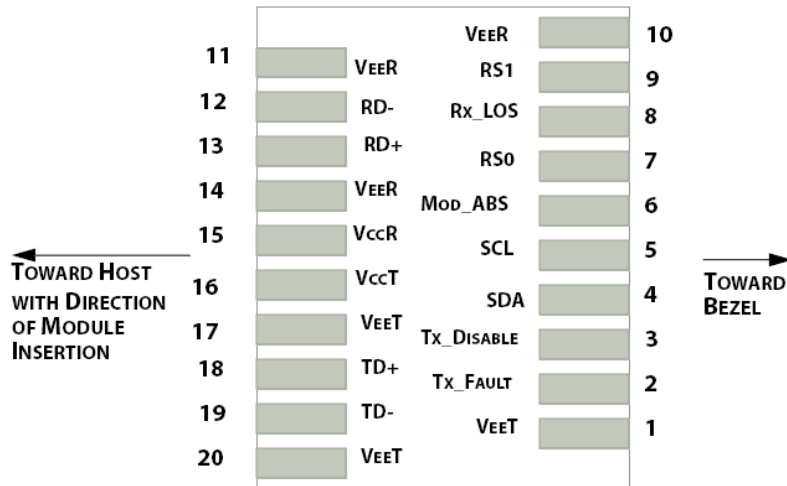

Figure1.Electrical Pin-out Details

## 7. Pin Descriptions

Pin	Symbol	Name/Description
1	VEET [1]	Transmitter Ground
2	Tx_FAULT [2]	Transmitter Fault
3	Tx_DIS [3]	Transmitter Disable. Laser output disabled on high or open
4	SDA [2]	2-wire Serial Interface Data Line
5	SCL [2]	2-wire Serial Interface Clock Line
6	MOD_ABS [4]	Module Absent. Grounded within the module
7	RS0 [5]	RS0 for Rate Select: Open or Low = Module supports ≤4.25Gbps High = Module supports 9.95 Gb/s to 10.3125 Gb/s
8	RX_LOS [2]	Loss of Signal indication. Logic 0 indicates normal operation
9	RS1 [5]	No connection required
10	VEER [1]	Receiver Ground
11	VEER [1]	Receiver Ground
12	RD-	Receiver Inverted DATA out. AC Coupled
13	RD+	Receiver DATA out. AC Coupled
14	VEER [1]	Receiver Ground
15	VCCR	Receiver Power Supply
16	VCCT	Transmitter Power Supply
17	VEET [1]	Transmitter Ground
18	TD+	Transmitter DATA in. AC Coupled
19	TD-	Transmitter Inverted DATA in. AC Coupled
20	VEET [1]	Transmitter Ground

**Notes:**

- [1] Module circuit ground is isolated from module chassis ground within the module.
- [2].should be pulled up with 4.7k – 10k ohms on host board to a voltage between 3.15V and 3.6V.
- [3]Tx\_Disable is an input contact with a 4.7 kΩ to 10 kΩ pullup to VccT inside the module.
- [4]Mod\_ABS is connected to VeeT or VeeR in the SFP+ module. The host may pull this contact up to Vcc\_Host with a resistor in the range 4.7 kΩ to 10 kΩ.Mod\_ABS is asserted “High” when the SFP+ module is physically absent from a host slot.
- [5] RS0 and RS1 are module inputs and are pulled low to VeeT with > 30 kΩ resistors in the module.

**8. Typical Interface Circuit**

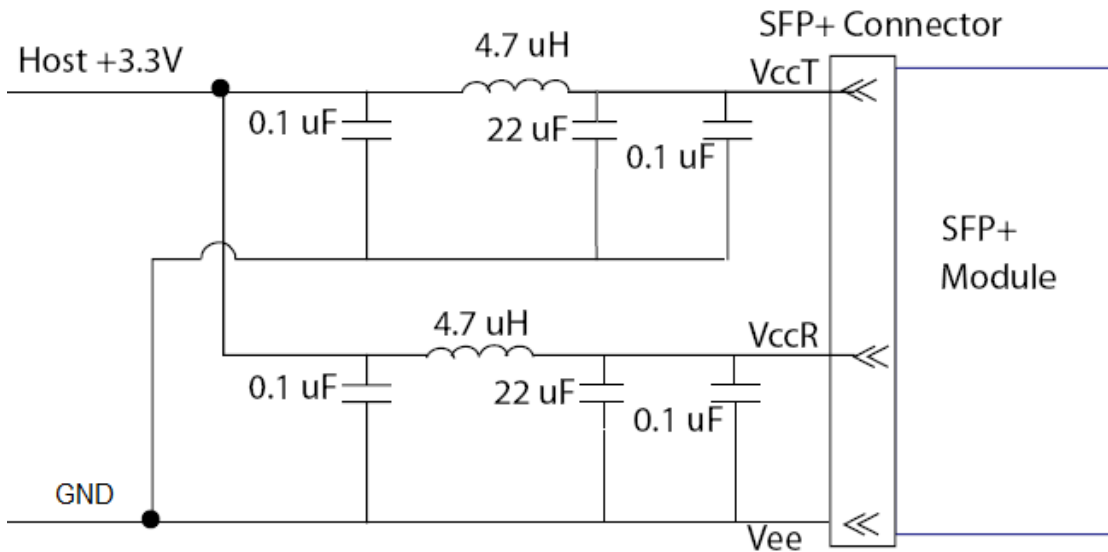

**Figure2. Host Board Power Supply Filters Circuit**

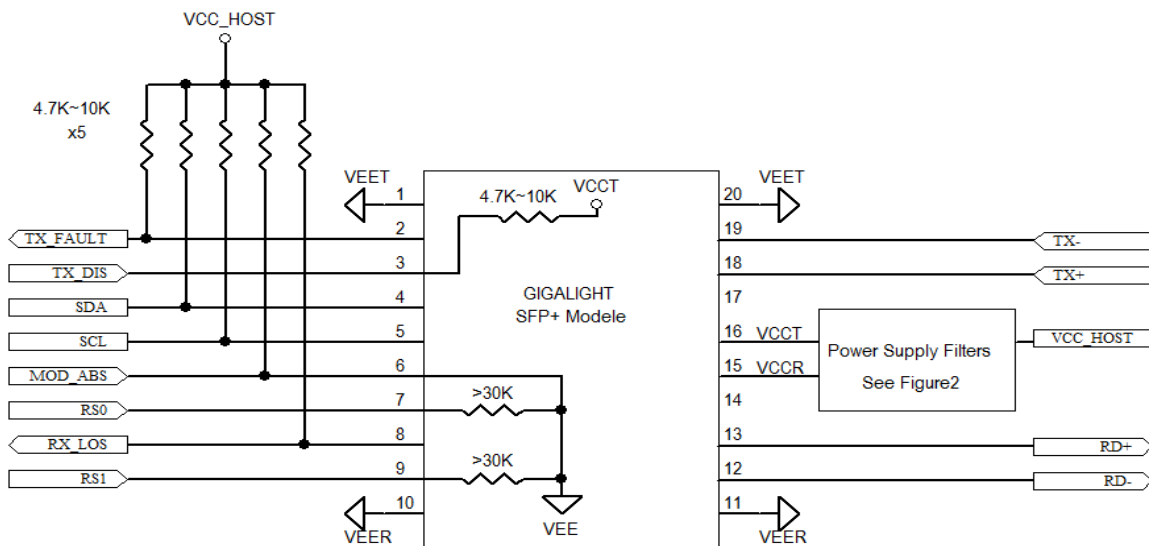

**Figure3. Host-Module Interface**

## 9. Package Dimensions

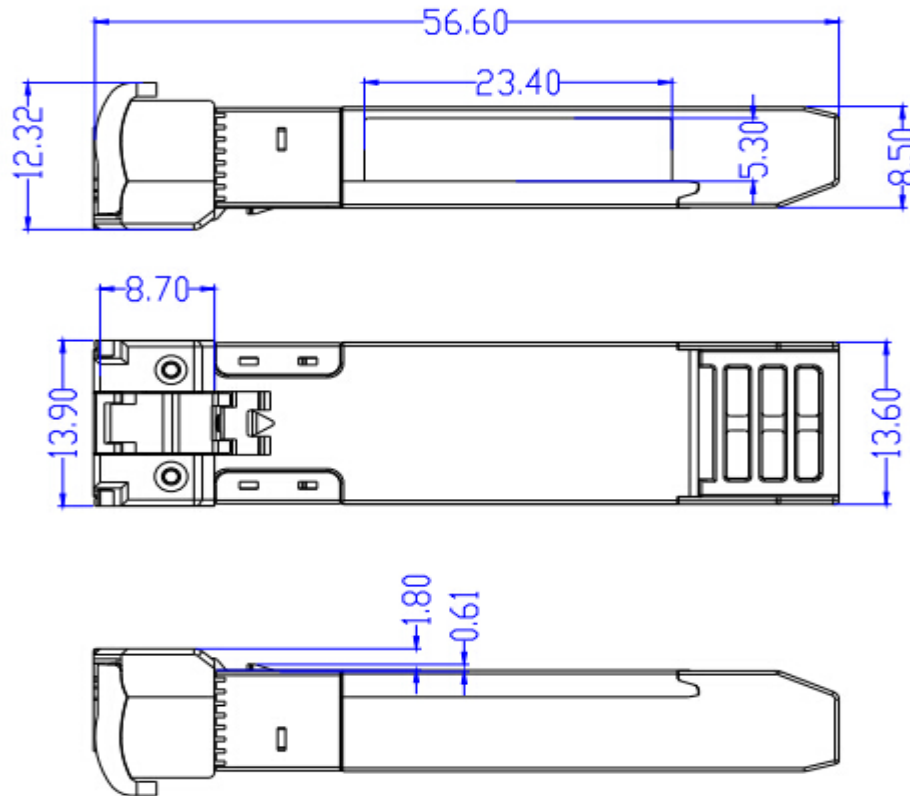

Figure6. Mechanical Specification

## 10. Ordering information

Part Number	Product Description
CWDM-SFP+-ER-47	SFP+,10Gbps ,1470nm,SMF,40KM, DDM,LC connector, -5°C ~ +70°C
CWDM-SFP+-ER-49	SFP+,10Gbps ,1490nm,SMF,40KM, DDM,LC connector, -5°C ~ +70°C
CWDM-SFP+-ER-51	SFP+,10Gbps ,1510nm,SMF,40KM, DDM,LC connector, -5°C ~ +70°C
CWDM-SFP+-ER-53	SFP+,10Gbps ,1530nm,SMF,40KM, DDM,LC connector, -5°C ~ +70°C
CWDM-SFP+-ER-55	SFP+,10Gbps ,1550nm,SMF,40KM, DDM,LC connector, -5°C ~ +70°C
CWDM-SFP+-ER-57	SFP+,10Gbps ,1570nm,SMF,40KM, DDM,LC connector, -5°C ~ +70°C
CWDM-SFP+-ER-59	SFP+,10Gbps ,1590nm,SMF,40KM, DDM,LC connector, -5°C ~ +70°C
CWDM-SFP+-ER-61	SFP+,10Gbps ,1610nm,SMF,40KM, DDM,LC connector, -5°C ~ +70°C