

## BIDI-SFP+-ER-27(33)

60M, BIDI SFP+,10 Gb/s, 1330/1270nm,SMF, 40KM ,DDM,LC connector, 0°C ~ +70°C

### PRODUCT FEATURES

- ◆ Supports 9.95 to 11.3Gb/s bit rates
- ◆ Simplex LC Connector
- ◆ Hot pluggable SFP+ footprint
- ◆ Uncooled 1270nm DFB transmitter, PIN photo-detector
- ◆ Uncooled 1330nm DFB transmitter, PIN photo-detector
- ◆ Applicable for 40km SMF connection
- ◆ Low power consumption, < 1.2W
- ◆ Digital Diagnostic Monitor Interface
- ◆ Optical interface compliant to IEEE 802.3ae 10GBASE-ER
- ◆ Electrical interface compliant to SFF-8431
- ◆ Operating case temperature:  
Commerical:0 to 70 °C
- ◆ Industrial:-40 to 85 °C



### APPLICATIONS

- ◆ 10GBASE-ER at 10.3125Gbps
- ◆ 10GBASE-EW at 9.953Gbps
- ◆ Other optical link

### PRODUCT DESCRIPTIONS

6COM BIDI-SFP+-ER-27(33) series single mode transceiver is small form factor pluggable module for optical data communications such as 10GBASE-ER/EW defined by IEEE 802.3ae. It is with the SFP+ 20-pin connector to allow hot plug capability. The BIDI-SFP+-ER module is designed for single mode fiber and operates at a nominal wavelength of 1270nm or 1330nm; The transmitter section uses a multiple quantum well DFB, which is class 1 laser compliant according to International Safety Standard IEC-60825. The receiver section uses an integrated InGaAs detector preamplifier (IDP) mounted in an optical header and a limiting post-amplifier IC. The transceiver designs are optimized for high performance and cost effective to supply customers the best solutions for telecommunication.

## Functional Diagram

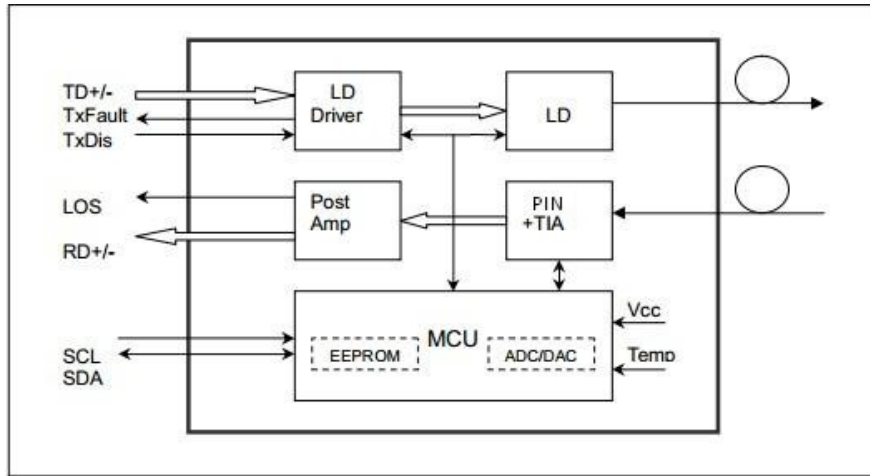

### 1. Absolute Maximum Ratings

Parameter	Symbol	Min.	Max.	Unit	Note
Supply Voltage	Vcc	-0.5	4.0	V	
Storage Temperature	TS	-40	85	°C	
Relative Humidity	RH	0	85	%	

**Note:** Stress in excess of the maximum absolute ratings can cause permanent damage to the transceiver.

### 2. General Operating Characteristics

Parameter	Symbol	Min.	Typ	Max.	Unit	Note
Data Rate	DR	9.95		10.3125	Gb/s	
Supply Voltage	Vcc	3.13	3.3	3.47	V	
Supply Current	Icc5			330	mA	
Operating Case Temp.	Tc	0		70	°C	
	Tl	-40		85		

### 3. Electrical Characteristics (T<sub>OP(C)</sub> = 0 to 70 °C, T<sub>OP(I)</sub> = -40 to 85 °C, V<sub>CC</sub> = 3.13 to 3.47 V)

Parameter	Symbol	Min.	Typ	Max.	Unit	Note
Transmitter						
Differential data input swing	V <sub>IN,PP</sub>	180		700	mVpp	1
Transmit Disable Voltage	VD	V <sub>CC</sub> -0.8		V <sub>CC</sub>	V	
Transmit Enable Voltage	VEN	V <sub>EE</sub>		V <sub>EE</sub> +0.8		
Input differential impedance	R <sub>in</sub>		100		Ω	
Receiver						
Differential data output swing	V <sub>out,pp</sub>	300		850	mVpp	2
Output rise time and fall time	T <sub>r</sub> , T <sub>f</sub>	28			Ps	3
LOS asserted	V <sub>LOS_F</sub>	V <sub>CC</sub> -0.8		V <sub>CC</sub>	V	4
LOS de-asserted	V <sub>LOS_N</sub>	V <sub>EE</sub>		V <sub>EE</sub> +0.8	V	4

**Notes:**

1. Connected directly to TX data input pins. AC coupling from pins into laser driver IC.
2. Into 100Ω differential termination.
3. 20 – 80%. Measured with Module Compliance Test Board and OMA test pattern. Use of four 1's and four 0's sequence in the PRBS 9 is an acceptable alternative.
4. LOS is an open collector output. Should be pulled up with 4.7kΩ – 10kΩ on the host board. Normal operation is logic 0; loss of signal is logic 1.

**4. Optical Characteristics** ( $T_{OP(C)} = 0$  to  $70\text{ }^{\circ}\text{C}$ ,  $T_{OP(I)} = -40$  to  $85\text{ }^{\circ}\text{C}$ ,  $V_{CC} = 3.13$  to  $3.47\text{ V}$ )

Parameter	Symbol	Min.	Typ	Max.	Unit	Note
<b>Transmitter</b>						
Operating Wavelength	$\lambda$	1260	1270	1280	nm	
		1320	1330	1340		
Ave. output power (Enabled)	PAVE	1		5	dBm	1
Side-Mode Suppression Ratio	SMSR	30			dB	
Extinction Ratio	ER	5			dB	
RMS spectral width	$\Delta\lambda$			1	nm	
Rise/Fall time (20%~80%)	Tr/Tf			50	ps	
Dispersion penalty	TDP			3.2	dB	
Relative Intensity Noise	RIN			-128	dB/Hz	
Output Optical Eye	Compliant with IEEE 0802.3ae					
<b>Receiver</b>						
Operating Wavelength	$\lambda$	1320	1330	1340	nm	
		1260	1270	1280		
Receiver Sensitivity	PSEN2			-15	dBm	2
Average Receive Power	PAVE			0.5	dBm	
Receiver Reflectance	Rrx			-12	dB	
LOS Assert	Pa	-30			dBm	
LOS De-assert	Pd			-17	dBm	
LOS Hysteresis	Pd-Pa	0.5			dB	

**Notes:**

1. Average power figures are informative only, per IEEE 802.3ae.
2. Measured with worst ER=6; BER<10<sup>-12</sup>; 2<sup>31</sup> – 1 PRBS.

## 5. Pin Defintion and Functions

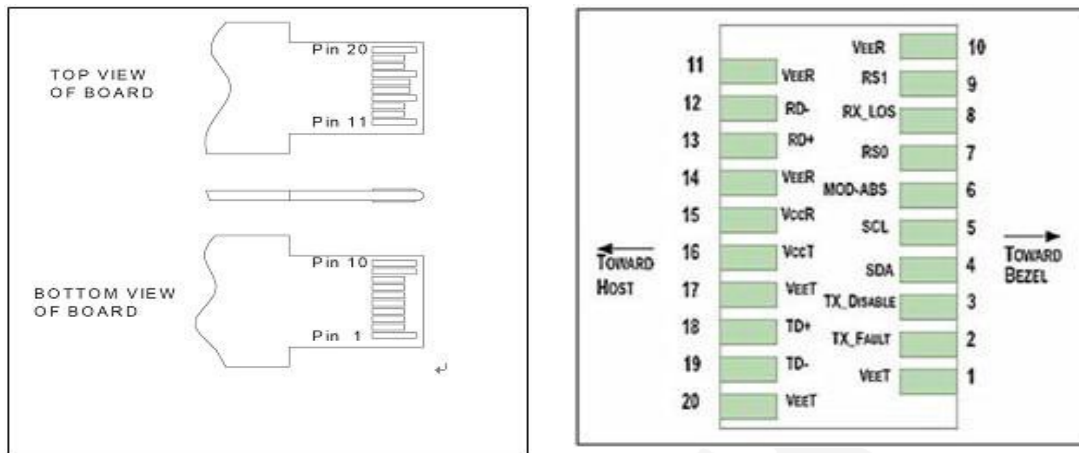

Pin	Symbol	Name/Description
1	VEER [1]	Transmitter Ground
2	Tx_FAULT [2]	Transmitter Fault
3	Tx_DIS [3]	Transmitter Disable. Laser output disabled on high or open
4	SDA [2]	2-wire Serial Interface Data Line
5	SCL [2]	2-wire Serial Interface Clock Line
6	MOD_ABS [4]	Module Absent. Grounded within the module
7	RS0	Rate Select 0
8	RX_LOS [2]	Loss of Signal indication. Logic 0 indicates normal operation
9	RS1 [5]	Rate Select 1
10	VEER [1]	Receiver Ground
11	VEER [1]	Receiver Ground
12	RD-	Receiver Inverted DATA out. AC Coupled
13	RD+	Receiver DATA out. AC Coupled
14	VEER [1]	Receiver Ground
15	VCCR	Receiver Power Supply
16	VCCT	Transmitter Power Supply
17	VEET [1]	Transmitter Ground
18	TD+	Transmitter DATA in. AC Coupled
19	TD-	Transmitter Inverted DATA in. AC Coupled
20	VEET [1]	Transmitter Ground

### Notes:

1. Module circuit ground is isolated from module chassis ground within the module.
2. should be pulled up with 4.7k – 10k ohms on host board to a voltage between 3.15V and 3.6V.
3. Tx\_Disable is an input contact with a 4.7 kΩ to 10 kΩ pullup to VccT inside the module.
4. Mod\_ABS is connected to VeeT or VeeR in the SFP+ module. The host may pull this contact up to Vcc\_Host with a resistor in the range 4.7 kΩ to 10 kΩ. Mod\_ABS is asserted “High” when the SFP+ module is physically absent from a host slot.

## 6. Serial Interface for ID and Digital Diagnostic Monitor

The BIDI-SFP+-ER-27(33) transceiver support the 2-wire serial communication protocol as defined in the SFP+ MSA. The standard SFP+ serial ID provides access to identification information that describes the transceiver's capabilities, standard interfaces, manufacturer, and other information. Additionally, This SFP+ transceivers provide an enhanced digital diagnostic monitoring interface, which allows real-time access to device operating parameters such as transceiver temperature, laser bias current, transmitted optical power, received optical power and transceiver supply voltage. It also defines a sophisticated system of alarm and warning flags, which alerts end-users when particular operating parameters are outside of a factory set normal range.

The SFP MSA defines a 256-byte memory map in EEPROM that is accessible over a 2-wire serial interface at the 8 bit address 1010000X (A0h), so the originally monitoring interface makes use of the 8 bit address (A2h), so the originally defined serial ID memory map remains unchanged. The structure of the memory map is shown in Table1.

2 wire address 1010000X (A0h)		2 wire address 1010001X (A2h)	
Address	Information	Address	Information
0~95	Serial ID Defined by SFP MSA (96 bytes)	0~55	Alarm and Warning Thresholds (56 bytes)
96~127	Vendor Specific (32 bytes)	56~95	Calibration Constants (40 bytes)
		96~119	Real Time Diagnostic Interface (24 bytes)
128~255	Reserved,SFF8079 (128 bytes)	120~127	Vender Specific (8 bytes)
		128~247	User Writable EEPROM (120 bytes)
		248~255	Vender Specific (8 bytes)

Table 1. Digital Diagnostic Memory Map (Specific Data Field Descriptions)

## 7. Digital Diagnostic Specifications

The BIDI-SFP+-ER-27(33) transceivers can be used in host systems that require either internally or externally calibrated digital diagnostics.

Parameter	Symbol	Units	Min.	Max.	Accuracy	Note
Transceiver temperature	DTemp-E	°C	-45	+90	±5°C	1,2
Transceiver supply voltage	DVoltage	V	2.8	4.0	±3%	
Transmitter bias current	DBias	mA	0	127	±10%	3
Transmitter output power	DTx-Power	dBm	-2	+6	±2dB	
Receiver average input power	DRx-Power	dBm	-20	+1	±2dB	

### Notes:

1. When Operating temp.=0~70 °C,the range will be min=-5,Max=+75
2. Internally measured
3. The accuracy of the Tx bias current is 10% of the actual current from the laser driver to the laser

## 8. Typical Interface Circuit

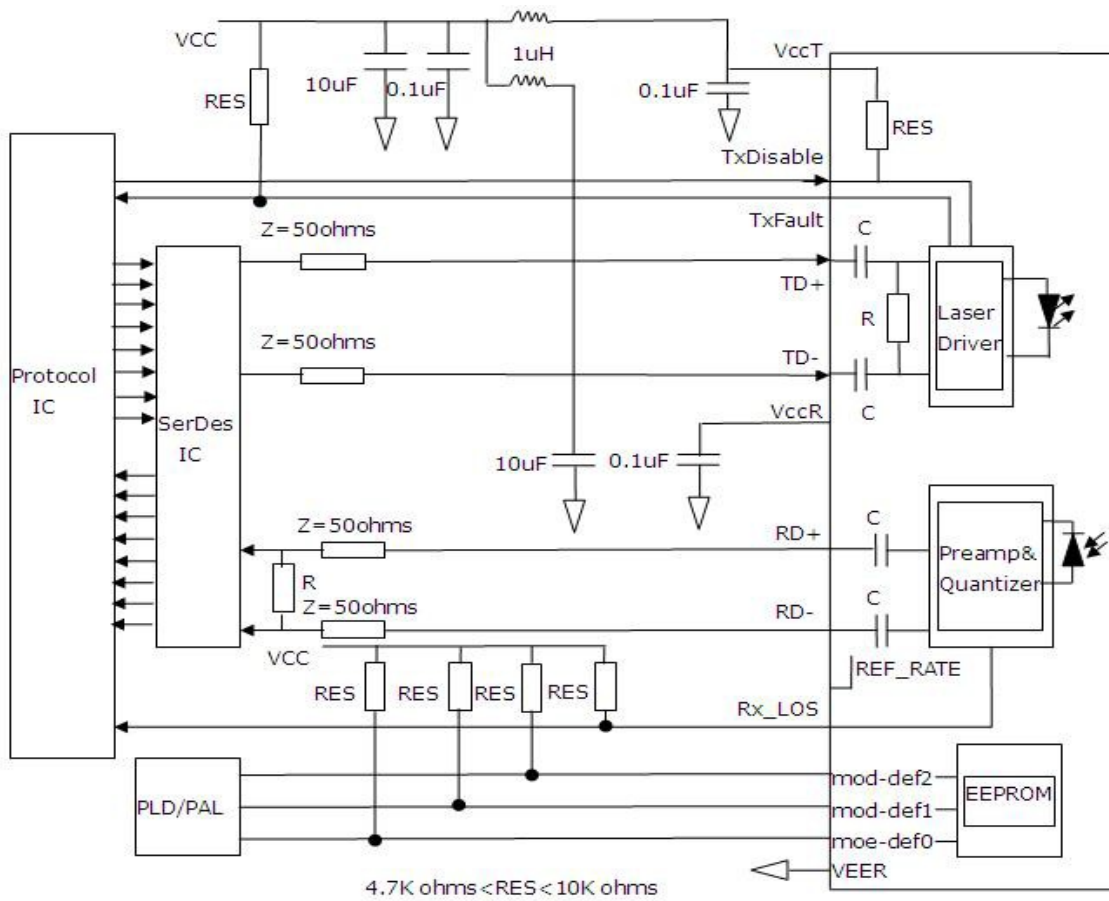

## 9. Recommended power supply filter

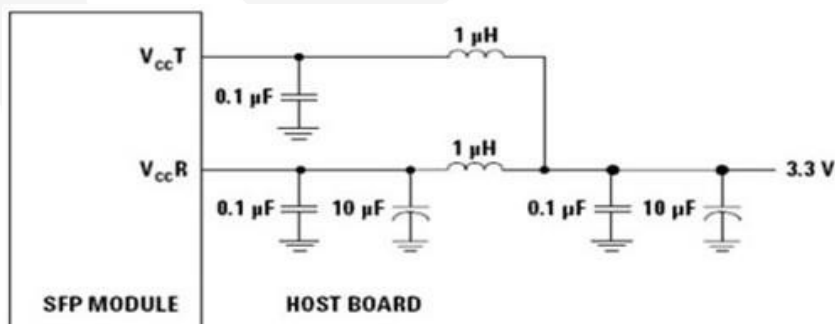

### Note:

Inductors with DC resistance of less than  $1\Omega$  should be used in order to maintain the required voltage at the SFP input pin with 3.3V supply voltage. When the recommended supply filtering network is used, hot plugging of the SFP transceiver module will result in an inrush current of no more than 30 mA greater than the steady state value

## 10. Package Dimensions

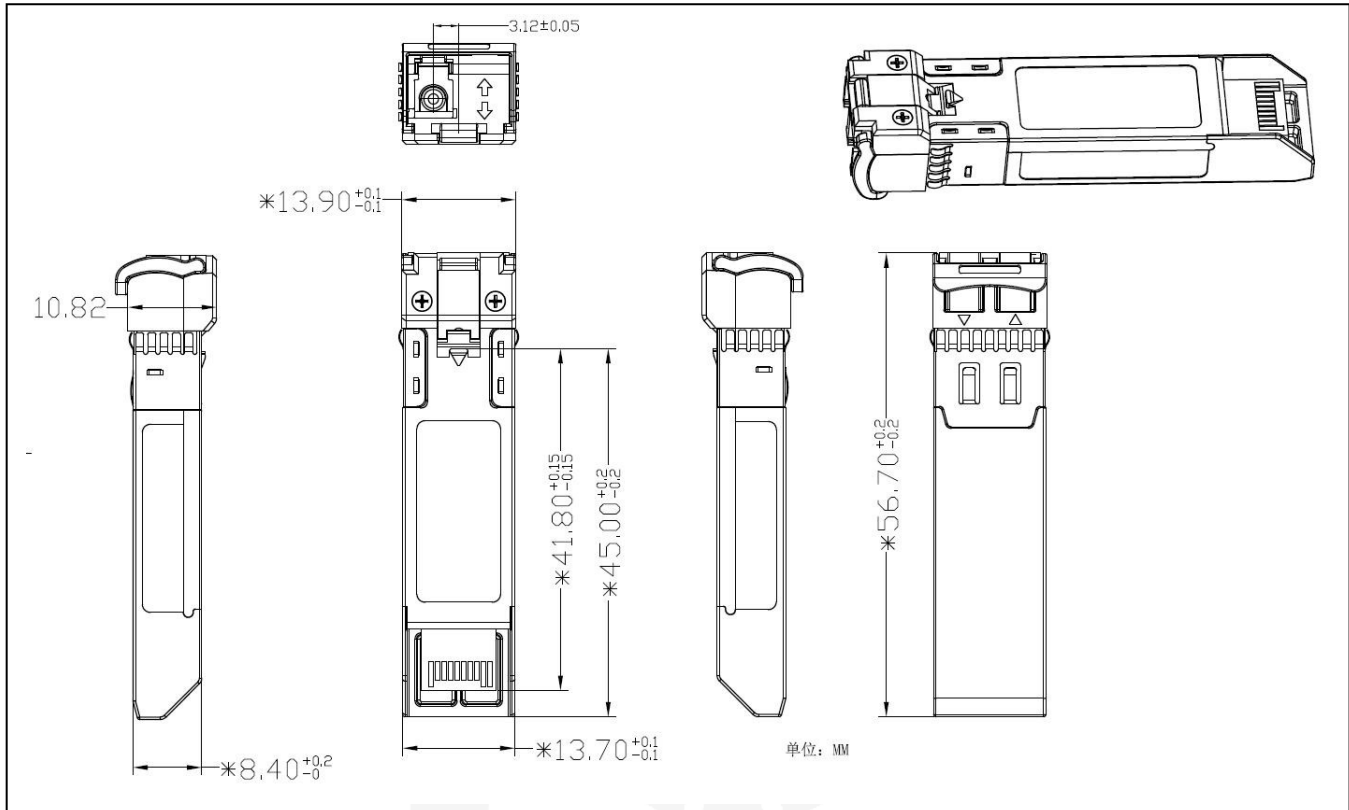

## 11. Ordering Information

Part Number	Description
BIDI-SFP+-ER-27	BIDI SFP+,10 Gb/s, 1270nm,SMF, 40KM ,DDM,LC connector, 0°C ~ +70°C
BIDI-SFP+-ER-33	BIDI SFP+,10 Gb/s, 1330nm,SMF, 40KM ,DDM,LC connector, 0°C ~ +70°C