

Product Specification

80km 100GBASE-ZR4 QSFP28 Optical Transceiver Module

6C-QSFP28-ZR4

PRODUCT FEATURES

- QSFP28 MSA compliant
- Hot pluggable 38 pin electrical interface
- 4 LAN-WDM lanes MUX/DEMUX design
- 4x25G electrical interface
- Maximum power consumption 6.5W
- LC duplex connector
- Supports 103.125Gb/s aggregate bit rate
- Up to 80km transmission on single mode fiber
- Operating case temperature: 0°C to 70°C
- Single 3.3V power supply
- RoHS 2.0 compliant

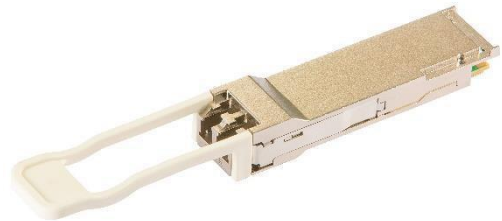

APPLICATIONS

- 100GBASE-ZR4 100G Ethernet
- Telecom networking

DESCRIPTIONS

6COM's 6C-QSFP28-ZR4 is designed for 80km optical communication applications. This module contains 4-lane optical transmitter, 4-lane optical receiver and module management block including 2 wire serial interface. The optical signals are multiplexed to a single-mode fiber through an industry standard LC connector. A block diagram is shown in Figure 1.

Transceiver Block Diagrams

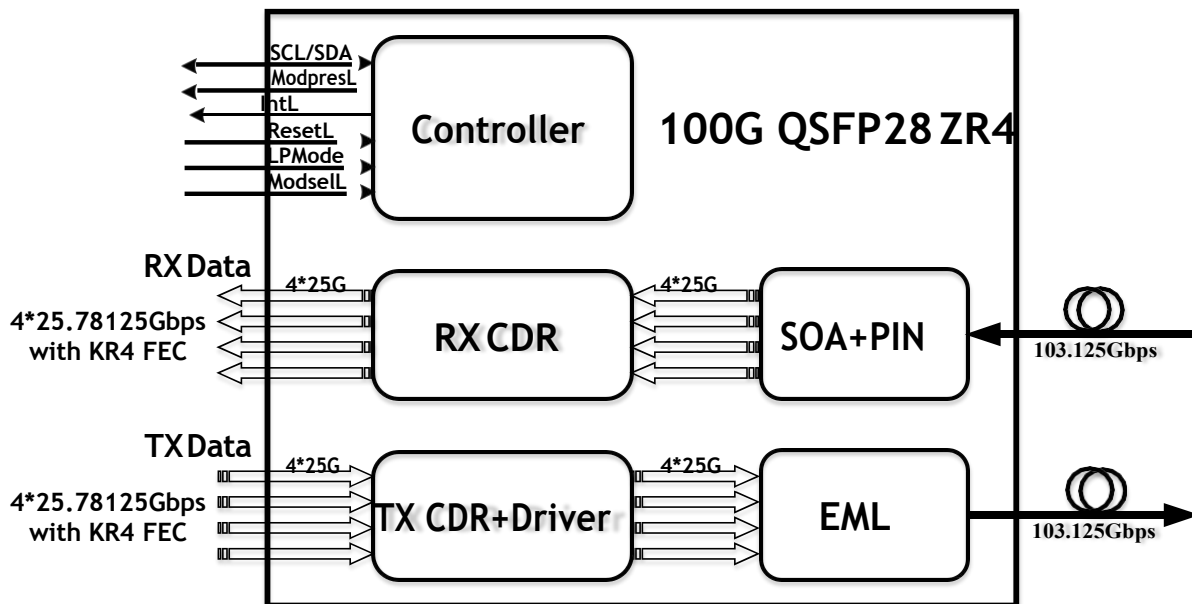

Figure 1. Transceiver Block Diagram

ModSelL:

The ModSelL is an input pin. When held low by the host, the module responds to 2-wire serial communication commands. The ModSelL allows the use of multiple modules on a single 2-wire interface bus. When the ModSelL is "High", the module shall not respond to or acknowledge any 2-wire interface communication from the host. ModSelL signal input node shall be biased to the "High" state in the module.

In order to avoid conflicts, the host system shall not attempt 2-wire interface communications within the ModSelL de-assert time after any modules are deselected. Similarly, the host shall wait at least for the period of the ModSelL assert time before communicating with the newly selected module. The assertion and de-asserting periods of different modules may overlap as long as the above timing requirements are met.

ResetL :

The ResetL pin shall be pulled to Vcc in the module. A low level on the ResetL pin for longer than the minimum pulse length (t_{Reset_init}) initiates a complete module reset, returning all user module settings to their default state. Module Reset Assert Time (t_{init}) starts on the rising edge after the low level on the ResetL pin is released. During the execution of a reset (t_{init}) the host shall disregard all status bits until the module indicates a completion of the reset interrupt. The module indicates this by asserting "low" an IntL signal with the

Data_Not_Ready bit negated. Note that on power up (including hot insertion) the module should post this completion of reset interrupt without requiring a reset.

LPMODE:

The LPMODE pin shall be pulled up to Vcc in the module. The pin is a hardware control used to put modules into a low power mode when high. By using the LPMODE pin and a combination of the Power override, Power_set and High_Power_Class_Enable software control bits (Address A0h, byte 93 bits 0,1,2).

ModPrsL:

ModPrsL is pulled up to Vcc_Host on the host board and grounded in the module. The ModPrsL is asserted "Low" when inserted and deasserted "High" when the module is physically absent from the host connector.

IntL:

IntL is an output pin. When IntL is "Low", it indicates a possible module operational fault or a status critical to the host system. The host identifies the source of the interrupt using the 2-wire serial interface. The IntL pin is an open collector output and shall be pulled to host supply voltage on the host board. The INTL pin is deasserted "High" after completion of reset, when byte 2 bit 0 (Data Not Ready) is read with a value of '0' and the flag field is read .

Pin Descriptions

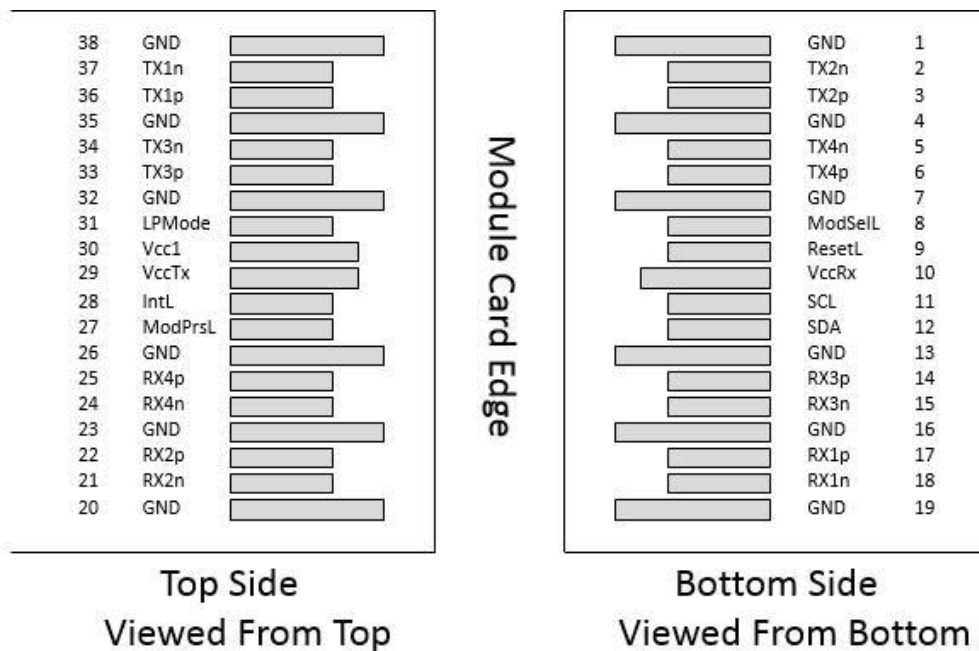

Figure 2. MSA compliant Connector

Pin	Symbol	Description	Notes
1	GND	Ground	1
2	Tx2n	Transmitter Inverted Data Input	
3	Tx2p	Transmitter Non-Inverted Data Input	
4	GND	Ground	1
5	Tx4n	Transmitter Inverted Data Input	
6	Tx4p	Transmitter Non-Inverted Data Input	
7	GND	Ground	1
8	ModSelL	Module Select	
9	ResetL	Module Reset	
10	Vcc Rx	+3.3V Power Supply Receiver	
11	SCL	2-wire serial interface clock	
12	SDA	2-wire serial interface data	
13	GND	Ground	1
14	Rx3p	Receiver Non-Inverted Data Output	
15	Rx3n	Receiver Inverted Data Output	
16	GND	Ground	1
17	Rx1p	Receiver Non-Inverted Data Output	
18	Rx1n	Receiver Inverted Data Output	
19	GND	Ground	1
20	GND	Ground	1
21	Rx2n	Receiver Inverted Data Output	
22	Rx2p	Receiver Non-Inverted Data Output	
23	GND	Ground	1
24	Rx4n	Receiver Non-Inverted Data Output	
25	Rx4p	Receiver Inverted Data Output	
26	GND	Ground	1
27	ModPrsL	Module Present	
28	IntL	Interrupt	
29	Vcc Tx	+3.3V Power supply transmitter	
30	Vcc1	+3.3V Power supply	
31	LPMODE	Low Power Mode	
32	GND	Ground	1
33	Tx3p	Transmitter Non-Inverted Data Input	
34	Tx3n	Transmitter Inverted Data Input	
35	GND	Ground	1
36	Tx1p	Transmitter Non-Inverted Data Input	
37	Tx1n	Transmitter Inverted Data Input	
38	GND	Ground	1

Notes

1.Circuit ground is internally isolated from chassis ground.

Absolute Maximum Ratings

It has to be noted that the operation in excess of any individual absolute maximum ratings might cause permanent damage to this module.

Parameter	Symbol	Min	Typ	Max	Unit	Notes
Maximum Supply Voltage	Vcc	0		3.6	V	
Storage Temperature	Ts	-40		85	°C	
Relative Humidity	RH	15		85	%	1
Damage Threshold, each lane	THd	6.5			dBm	

Notes

1. Non-condensing

Operating Environments

Electrical and optical characteristics below are defined under this operating environment, unless otherwise specified.

Parameter	Symbol	Min	Typ	Max	Unit
Supply Voltage	Vcc	3.135	3.3	3.465	V
Case Temperature	Top	0		70	°C
Link Distance with G.652				80	km

Electrical Characteristics

Parameter	Symbol	Min	Typ	Max	Unit	Note
Power dissipation				6.5	W	
Supply Current	Icc			1.8759	A	Steady state
Transmitter						
Data Rate, each lane			25.78125		Gbps	
Differential Voltage pk-pk	Vpp			900	mV	At 1 MHz
Common Mode Voltage	Vcm	-350		2850	mV	
Transition time	Trise/Tfall	10			ps	20%~80%

Differential Termination Resistance Mismatch				10	%	
Eye width	EW15	0.46			UI	
Eye height	EH15	95			mV	
Receiver						
Data Rate, each lane			25.78125		Gbps	
Differential Termination Resistance Mismatch				10	%	At 1 MHz
Differential output voltage swing	Vout, pp			900	mV	
Common Mode Noise, RMS	Vrms			17.5	mV	
Transition time	Trise/Tfall	12			ps	20%~80%
Eye width	EW15	0.57			UI	
Eye height	EH15	228			mV	

Optical Characteristics

100GBASE-ZR4 Operation (EOL, TOP = 0 to +70 °C , VCC = 3.135 to 3.465 Volts)

Parameters	Unit	min	type	max	Note
Transmitter					
Signaling Speed per Lane	Gb/s	25.78125 ± 100 ppm			
Transmit wavelengths	nm	1294.53		1296.59	
		1299.02		1301.09	
		1303.54		1305.63	
		1308.09		1310.19	
Side-Mode Suppression Ratio (SMSR)	dB	30			
Total Average Launch Power	dBm	8.0		12.5	
Average launch power, each lane	dBm	2.0		6.5	
Difference in launch power between any two lanes(Average and OMA)	dBm			3	
Average launch power of OFF transmitter, each lane	dBm			-30	
Extinction Ratio (ER)	dB	6			

RIN OMA	dB/Hz			-130	
Optical return loss tolerance	dB			20	
Transmitter reflectance	dB			-12	
Transmitter eye mask definition {X1, X2, X3, Y1, Y2, Y3}		{0.25, 0.4, 0.45, 0.25, 0.28, 0.4}			1
Mask margin	%	5			
Receiver					
Signaling Speed per Lane	Gb/s	25.78125 ± 100 ppm			
Receive wavelengths	nm	1294.53		1296.59	
		1299.02		1301.09	
		1303.54		1305.63	
		1308.09		1310.19	
Average receiver power, each lane	dBm	-28		-3.5	
Receiver power, each lane(OMA)	dBm			-3.5	
Receiver reflectance	dB			-26	
Receiver sensitivity Average, each lane	dBm			-28	1
Receiver 3 dB electrical upper cutoff frequency, each lane	GHz			31	
Damage threshold, each lane	dBm	6.5			
LOS Assert	dBm	-40			
LOS Deassert	dBm			-29	
LOS Hysteresis	dB	0.5			

Notes

1, Sensitivity is specified at BER@5E-5 with FEC

EEPROM Definitions

Lower Memory Map

Address	Type	Size	Name	Description	Value(Hex)	Remarks	
0	R	1	Identifier	Identifier			
1	R	1	Status	Revision Compliance			
2	R	1	Status	Flat_mem/ IntL/Data_Not_Ready			
3	R	1	Interrupt Flags	Latched TX/RX LOS indicator			
4	R	1		Latched TX Adaptive EQ/TX Transmitter/Laser fault indicator			
5	R	1		Latched TX/RX CDR LOL indicator			
6	R	1		Latched temperature A/W / Initialization complete flag			
7	R	1		Latched supply voltage A/W			
8	R	1		Vendor Specific			
9~10	R	2		Latched RX power A/W			
11~12	R	2		Latched TX bias A/W			
13~14	R	2		Latched TX power A/W			
15~18	R	4		Reserved			
19-21	R	2		Vendor Specific			
22-23	R	2		Device monitors	Module temperature		
24-25	R	2			Reserved		
26-27	R	2			Supply voltage		
28-29	R	2	Reserved				
30-33	R	4	Vendor Specific				
34-35	R	2	Power monitors	RX input power, channel 1			
36-37	R	2		RX input power, channel 2			
38-39	R	2		RX input power, channel 3			
40-41	R	2		RX input power, channel 4			
42-43	R	2	LD Bias Monitors	TX bias, channel 1			
44-45	R	2		TX bias, channel 2			

Address	Type	Size	Name	Description	Value(Hex)	Remarks
46-47	R	2		TX bias, channel 3		
48-49	R	2		TX bias, channel 4		
50-51	R	2	Power monitors	TX power, channel 1		
52-53	R	2		TX power, channel 2		
54-55	R	2		TX power, channel 3		
56-57	R	2		TX power, channel 4		
58-73	R	16		Reserved		
74-81	R	8		Vendor Specific		
82-85	R	4		Reserved		
86	RW	1	Control	Tx Disable		
87	RW	1		Rx_Rate_select		
88	RW	1		Tx_Rate_select		
89~92	RW	4		Rx_Application_Select		
93	RW	1		Power		
94~97	RW	4		Tx_Application_Select		
98	RW	1		TX/RX CDR_control		
99	RW	1			Reserved	
100-104	RW	4	Free Side Device and Channel Masks	Module and Channel Masks		
105	RW	1		Vendor Specific		
106	RW	1		Vendor Specific		
107	RW	1		Reserved		
108-109	R	2	Free Side Device Properties	Most significant byte of propagation delay		
110	R	1		Advanced Low Power Mode / Far Side Managed / Min Operating Voltage		
111-112	RW	2	Assigned for use by PCI Express	PCI		
113	R	1	Free Side Device Properties	End Implementation		

Address	Type	Size	Name	Description	Value(Hex)	Remarks
114-118	RW	6		Reserved		
119-122	W	4		Password Change Entry Area		
123-126	W	4		Password Entry Area		
127	RW	1		Page Select Byte		

Upper Memory Map Page 00h

Address	Type	Size	Name	Description	Value(Hex)	Remarks
128	R	1	Identifier	Identifier Type of serial Module		
129	R	1	Ext. Identifier	Extended Identifier to free side device. Includes power classes, CLEI codes, CDR capability		
130	R	1	Connector	Code for connector type		
131	R	1	Specification compliance	10/40G/100G Ethernet Compliance Codes		
132	R	1		SONET Compliance Codes		
133	R	1		SAS/SATA Compliance Codes		
134	R	1		Gigabit Ethernet Compliant Codes		
135~136	R	1		Fibre Channel link length/Fibre Channel Transmitter Technology		
137	R	1		Fibre Channel transmission media		
138	R	1		Fibre Channel Speed		
139	R	1	Encoding	Code for serial encoding algorithm.		
140	R	1		Nominal bit rate, units of 100Mbps. For BR>25.4G, set this to FFh and use Byte 222.		
141	R	1		QSFP+ Rate Select Version 2.		
142	R	1		Link length supported for SMF fiber in km.		
143	R	1	Length	Length(OM3 50 um)		
144	R	1		Length(OM2 50 um)		
145	R	1		Length(OM1 62.5 um)		
146	R	1		Length(OM5 50um)		
147	R	1	Device tech- nology	Device technology		



Address	Type	Size	Name	Description	Value(Hex)	Remarks
148	R	1	Vendor name	Free side device vendor		
149	R	1				
150	R	1				
151	R	1				
152	R	1				
153	R	1				
154	R	1				
155	R	1				
156	R	1				
157	R	1				
158	R	1				
159	R	1				
160	R	1				
161	R	1				
162	R	1				
163	R	1				
164	R	1	Extended Module			
165~167	R	1	Vendor OUI			
168	R	1	Vendor PN	Part number provided by free side device vendor		
169	R	1				
170	R	1				
171	R	1				
172	R	1				
173	R	1				
174	R	1				
175	R	1				
176	R	1				
177	R	1				

Address	Type	Size	Name	Description	Value(Hex)	Remarks
178	R	1				
179	R	1				
180	R	1				
181	R	1				
182	R	1				
183	R	1				
184	R	1	Vendor rev	Revision level for part number provided by vendor		
185	R	1				
186	R	1	Wavelength	Nominal laser wavelength (wavelength=value/20 in nm)		
187	R	1				
188	R	1	Wavelength tolerance	Guaranteed range of laser wavelength(+/- value) from nominal wavelength. (wavelength Tol.=value/200 in nm)		
189	R	1				
190	R	1	Max case temp	Maximum case temperature in degrees C		
191	R	1	C_BASE	Check code for base ID fields		
192	R	1	Link codes	Extended Specification Compliance Codes		
193	R	1	Options	TX Input Equalization Auto Adaptive Capable not implemented, TX Input Equalization Fixed Programmable Settings implemented, RX Output Emphasis Fixed Programmable Settings implemented, RX Output Amplitude Fixed Programmable Settings implemented		
194	R	1		Tx CDR LOL Flag, Rx CDR LOL Flag, RX Squelch Disable, RX Output Disable, TX Squelch Disable, TX Squelch		

Address	Type	Size	Name	Description	Value(Hex)	Remarks
195	R	1		Memory page 02h implemented, Memory page 01h implemented, Active control of the select bits in the upper memory table is required to change rates, Tx_DISABLE and serial output implemented, Tx_FAULT signal implemented, Tx Loss of Signal implemented		
196	R	1	Vendor SN	Serial number provided by vendor		
197	R	1				
198	R	1				
199	R	1				
200	R	1				
201	R	1				
202	R	1				
203	R	1				
204	R	1				
205	R	1				
206	R	1				
207	R	1				
208	R	1				
209	R	1				
210	R	1				
211	R	1				
212	R	1	Date Code	Vendor's manufacturing date code		
213	R	1				
214	R	1				
215	R	1				
216	R	1				
217	R	1				



Address	Type	Size	Name	Description	Value(Hex)	Remarks
218	R	1				
219	R	1				
220	R	1	Diagnostic Monitoring Type	Average RX power measurement, Transmitter power measurement supported		
221	R	1	Enhanced Options	Indicates which optional enhanced features are implemented (if any) in the free side device.		
222	R	1	BR, nominal	Nominal bit rate per channel, units of 250Mbps.		
223	R	1	CC_EXT	Check Code for Address 192 to 222		
224	R	1	Vendor Specific			
225	R	1				
226	R	1				
227	R	1				
228	R	1				
229	R	1				
230	R	1				
231	R	1				
232	R	1				
233	R	1				
234	R	1				
235	R	1				
236	R	1				
237	R	1				
238	R	1				
239	R	1				
240	R	1	Vendor Specific			
241	R	1	Vendor Specific			
242	R	1	Vendor Specific			
243	R	1		Reserved		

Address	Type	Size	Name	Description	Value(Hex)	Remarks
244	R	1				
245	R	1				
246	R	1				
247	R	1				
248	R	1				
249	R	1				
250	R	1	Checksum			
251	R	1	Vendor Specific			
252	R	1				
253	R	1				
254	R	1				
255	R	1				

Digital Diagnostic Monitoring Functions

6C-QSFP28-ZR4 support the I2C-based Diagnostic Monitoring Interface (DMI) defined in document .

The host can access real-time performance of transmitter and receiver optical power, temperature, supply voltage and bias current.

Performance Item	Related Bytes(A0[00] memory)	Monitor Error	Notes
Module temperature	22 to 23	+/-3°C	1, 2
Module voltage	26 to 27	< 3%	2
LD Bias current	42 to 49	< 10%	2
Transmitter optical power	50 to 57	< 3dB	2
Receiver optical power	34 to 41	< 3dB	2

Note

- 1, Actual temperature test point is fixed on module case around Laser.
- 2, Full operating temperature range

Alarm and Warning Thresholds

6C-QSFP28-ZR4 support alarms function, indicating the values of the preceding basic performance are lower or higher than the thresholds.

Performance Item	Alarm Threshold Bytes(A0[03] memory)	Unit	Low threshold	High threshold
Temp Alarm	128 to 131	℃	-10	80
Temp Warning	132 to 135	℃	0	70
Voltage Alarm	144 to 147	V	2.97	3.63
Voltage Warning	148 to 151	V	3.135	3.465
TX Power Alarm	192 to 195	dBm	-1	8.2
TX Power Warning	196 to 199	dBm	2	6.5
RX Power Alarm	176 to 179	dBm	-31	-0.5
RX Power Warning	180 to 183	dBm	-28	-3.5

Mechanical Specifications

6COM's 100G ZR4 QSFP28 transceivers are compatible with the QSFP28 Specification for pluggable form factor modules.

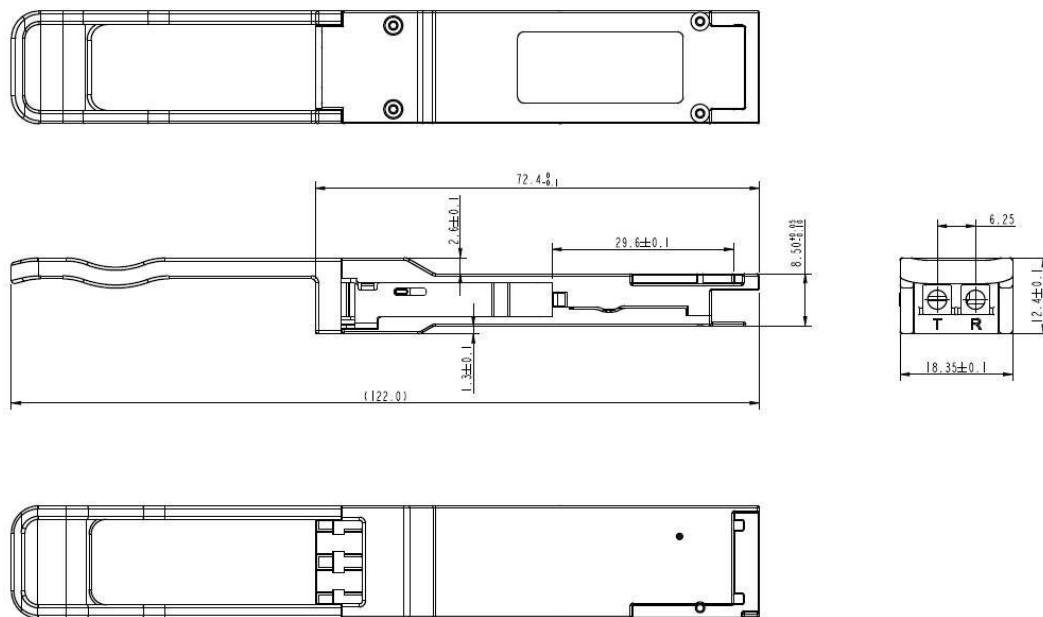

Figure 3. Mechanical Dimensions

Regulatory Compliance

Feature	Standard	Performance
Safety		
TUV	EN 60950-1	TUV certificate
	EN/IEC 60825-1:2007,Edition 2	
	EN/IEC 60825-1:2014,Edition 3	
	EN/IEC 60825-2:2004+A1:2006+A2:2010	
Electromagnetic Compatibility		
Radiated emissions	EMC Directive 2014/30/EU	Class B digital device with a minimum -6dB margin to the limit when tested with a metal enclosure. Final margin may vary depending on system application, good system EMI design practice, ie: suitable metal enclosure and well-bonding, is required to achieve Class B margins at the system level. Tested frequency range: 30 MHz to 40 GHz or 5th harmonic (5 times the highest frequency), whichever is less.
	EN 55032	
	CISPR 32	
	AS/NZS CISPR 32	
ESD	EN 55024	Withstands discharges of ± 8 k V contact, ± 15 k V air.
	CISPR 24	
	IEC/EN 61000-4-2	
Radiated immunity	EN 55024	Field strength of 10 V/m from 80 MHz to 6 GHz.
	CISPR 24	
	IEC/EN 61000-4-3	
Restriction of Hazardous Substances		
RoHS	EU Directive 2011/65/EU (EU) 2015/863	

ESD Design

Normal ESD precautions are required during the handling of this module. This transceiver is shipped in ESD protective packaging. It should be removed from the packaging and otherwise handled in an ESD protected environment utilizing standard grounded benches, floor mats, and wrist straps.

Parameter	Threshold value	Notes
ESD of high-speed pins	1KV	Human Body Model
ESD of low-speed pins	2KV	Human Body Model
Air discharge during operation	15KV	
Direct contact discharges to the case	8KV	

Safety Specification Design



Cautions

- 1) Do not look into fiber end faces without eye protection using an optical meter (such as magnifier and microscope) within 100 mm, unless you ensure that the laser output is disabled. When operating an optical meter, observe the operation requirements.
- 2) The RX input optical power cannot be higher than the damage threshold. You need the optical attenuator with RX in order to meet the input optical power range if necessary.
- 3) The 6C-QSFP28-ZR4 is the customized module, it can only interconnect with the 6C-QSFP28-ZR4 module. CAUTION: Use of controls or adjustments or performance of procedures other than those specified herein may result in hazardous radiation exposure.



Ordering Information

Part Number	Description
6C-QSFP28-ZR4	100GBASE-ZR4 80km QSFP28, Pull-tap, refer to Figure3

Nameplate information

TBD

END