

## 6C-GPON-OLT-7

6COM,GPON-OLT,1.25Gb/s,1490nm,SMF,20KM,DDM,SC connector, 0°C to +70°C

### FEATURES

- ◆ Single Fiber Transceiver with single mode SC receptacle
- ◆ 1490nm continuous-mode transmitter with DFB laser
- ◆ 1310nm burst-mode receiver with APD-TIA
- ◆ Single 3.3V power supply
- ◆ Reset burst-mode receiver design
- ◆ Burst mode signal detect output which is LVTTTL compatible.
- ◆ Burst mode received signal strength indication (RSSI) output
- ◆ 20Km Reach 28dB link budget
- ◆ Complies with ITU-T G984.2 Class B+
- ◆ Digital diagnostic interface compliant with SFF-8472 Rev 9.4 ,
- ◆ Complies with RoHS directive (2002/95/EC)
- ◆ Operating case temperature:  
Standard : 0 to +70°C



### APPLICATIONS

- ◆ Gigabit Passive Optical Networks (G-PON) – OLT side

### DESCRIPTION

The 6C-GPON-OLT-7 transceiver is the high performance module for single fiber by using 1490nm continuous-mode transmitter and 1310nm burst-mode receiver. It is optical line terminal (OLT) for ITU-T G984.2. The optical transceiver is compliant with the Small Form- Factor Pluggable (SFP) Multi-Source Agreement (MSA).

The transmitter section uses a 1490nm DFB LD with automatic power control (APC) function and temperature compensation circuitry to ensure stable extinction ratio over all operating temperature range. is Class I laser compliant IEC825 and CDRH standards. The receiver has a hermetically packaged burst-mode APD-TIA (trans-impedance amplifier) pre-amplifier and a burst-mode limiting amplifier with LVPECL compatible differential outputs.

The receiver also includes the function of burst mode signal detect output and fast RSSI output which is enabled by a trigger. When the burst optical power is on, the receiver outputs high level; when the burst

optical power is off, the receiver outputs low level. Fast RSSI function can satisfy more severe timing demand to monitor the power from any ONU.

## 1. Absolute Maximum Ratings

Parameter	Symbol	Min.	Max.	Units	Notes
Storage Temperature	Tst	-40	+85	°C	-
Operating Case Temperature	Tc	0	70	°C	-
Operating Humidity	RH	5	90	%	Non-condensing
Input Voltage	-	GND	Vcc	V	-
Power Supply Voltage	Vcc-Vee	0	3.6	V	-

## 2. Recommended Operating Conditions

Parameter	Standard	Symbol	Min	Typical	Max	Unit
Operating Case Temperature	Standard	Tc	0	-	+70	°C
Power Supply Voltage		Vcc	3.13	3.3	3.47	V
Power Supply Current		Icc	-	-	500	mA

## 3. Optical and Electrical Characteristics

Parameter	Symbol	Min	Typ	Max	Unit	Notes
<b>Transmitter</b>						
Data Rate			2.5		Gb/S	
Centre Wavelength	$\lambda_c$	1480		1500	nm	
Spectral Width	$\Delta\lambda$		0.4	1	nm	
Side Mode Suppression Ratio	SMSR	30			dB	
Average Output Power	Pout	7			dBm	1
Extinction Ratio	ER	10			dB	
Average Launch Power-OFF Transmitter	Poff			-40	dBm	
Optical Eye Diagram		Compliant with G984.2				
Optical Rise/Fall Time (20%~80%)	tr/tf			160	ps	
Data Input Swing Differential	VIN	200		2400	mV	2
Input Differential Impedance	ZIN	90	100	110	$\Omega$	
TX Disable	Disable	2.0		Vcc	V	
	Enable	0		0.8	V	
TX Fault	Fault	2.0		Vcc	V	
	Normal	0		0.8	V	
<b>Receiver</b>						
Data Rate			1.25		Gb/S	
Centre Wavelength	$\lambda_c$	1260		1360	nm	
Receiver Sensitivity	Sen			-32	dBm	3
Receiver Overload	Sat	-8			dBm	3
Receiver CID Tolerance		72			Bit	
Receiver Reflectance				-20	dB	
Data Output Voltage - High	VOH	VccR -1.05		VccR -0.85	V	4
Data Output Voltage - Low	VOL	VccR -1.84		VccR -1.60	V	4
Burst Detect De-assert	BSD_D	-45			dBm	
Burst Detect Assert	BSD_A			-34	dBm	
Burst Detect Hysteresis		1		6	dBm	

BRST_Det High	V_DETH	2.4		VCC	V	
BRST_Det Low	V_DETL	0		0.4	V	
Reciever Power DDM (RSSI)Err	RXDDM			+/-3	dBm	5

**Notes:**

1. The optical power is launched into SMF.
2. PECL input, internally AC-coupled and terminated.
3. Measured with a PRBS 2<sup>23</sup>-1 test pattern @1250Mbps, BER ≤1×10<sup>-10</sup>.
4. Internally DC-coupled.
5. RSSI DDM working range is between -8 to -28 dBm. RSSI DDM accuracy is better than +/- 3dB for input power levels between -12 to -28 dBm, the accuracy reduces to +/- 5 dBm for other input power levels.

**4. Diagnostics Specification**

Parameter	Range	Unit	Accuracy	Calibration
Temperature	0 to +70	°C	±3°C	Internal / External
Voltage	3.0 to 3.6	V	±3%	Internal / External
Bias Current	0 to 100	mA	±10%	Internal / External
TX Power	1.5 to 5	dBm	±3dB	Internal / External
RX Power	-28 to -8	dBm	±3dB	Internal / External

**5. Timing Characteristics for Digital RSSI**

Parameter	Symbol	Min.	TYP	MAX	UNITS
Trigger delay	Td	30			ns
Sample time	Ts	300			ns
Internal I2C Delay	TI2C			500	us
Digital RSSI		Figure 1			

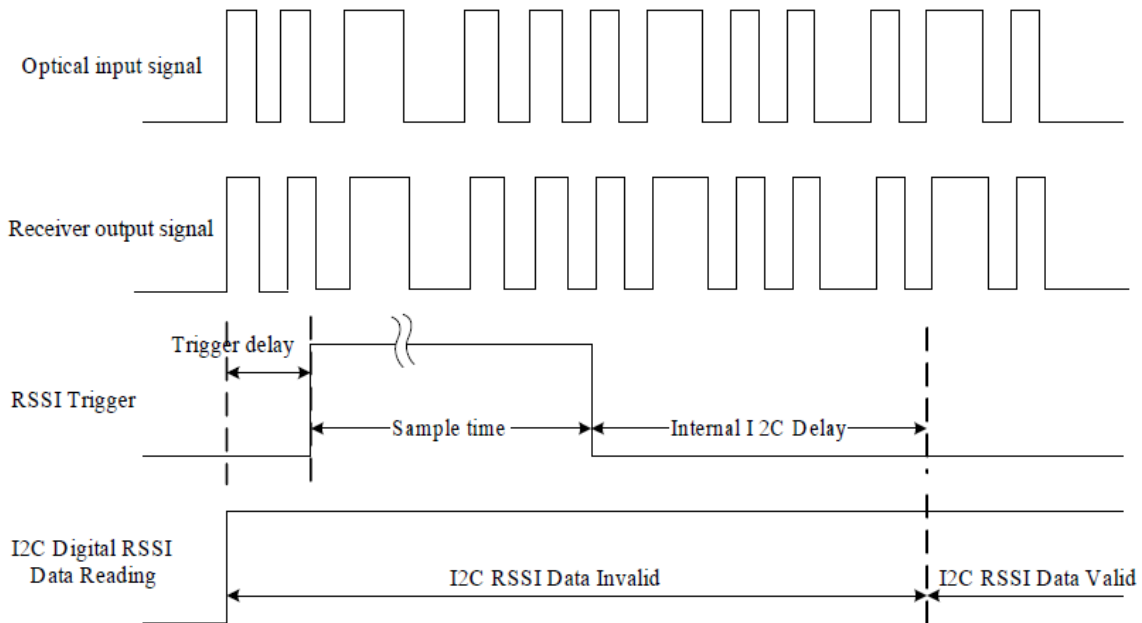

**Figure 1 Digital RSSI Timing**

## 6. Timing Characteristics for RESET

Parameter	Symbol	Min.	TYP	MAX	UNITS
RESET Input Signal (RESET+)	Reset	LVTTTL			
RESET Signal Width	Tr		24		Bits
Guard time	Tg	32			Bits
Preamble time	Tp	44			Bits
Reset Delay	$\Delta t$			Tg - Tr	Bits
Burst Signal Detect On	T_BSD_On			20	ns
Burst Signal Detect Off	T_BSD_Off			20	ns
IRESET Timing		Figure 2			

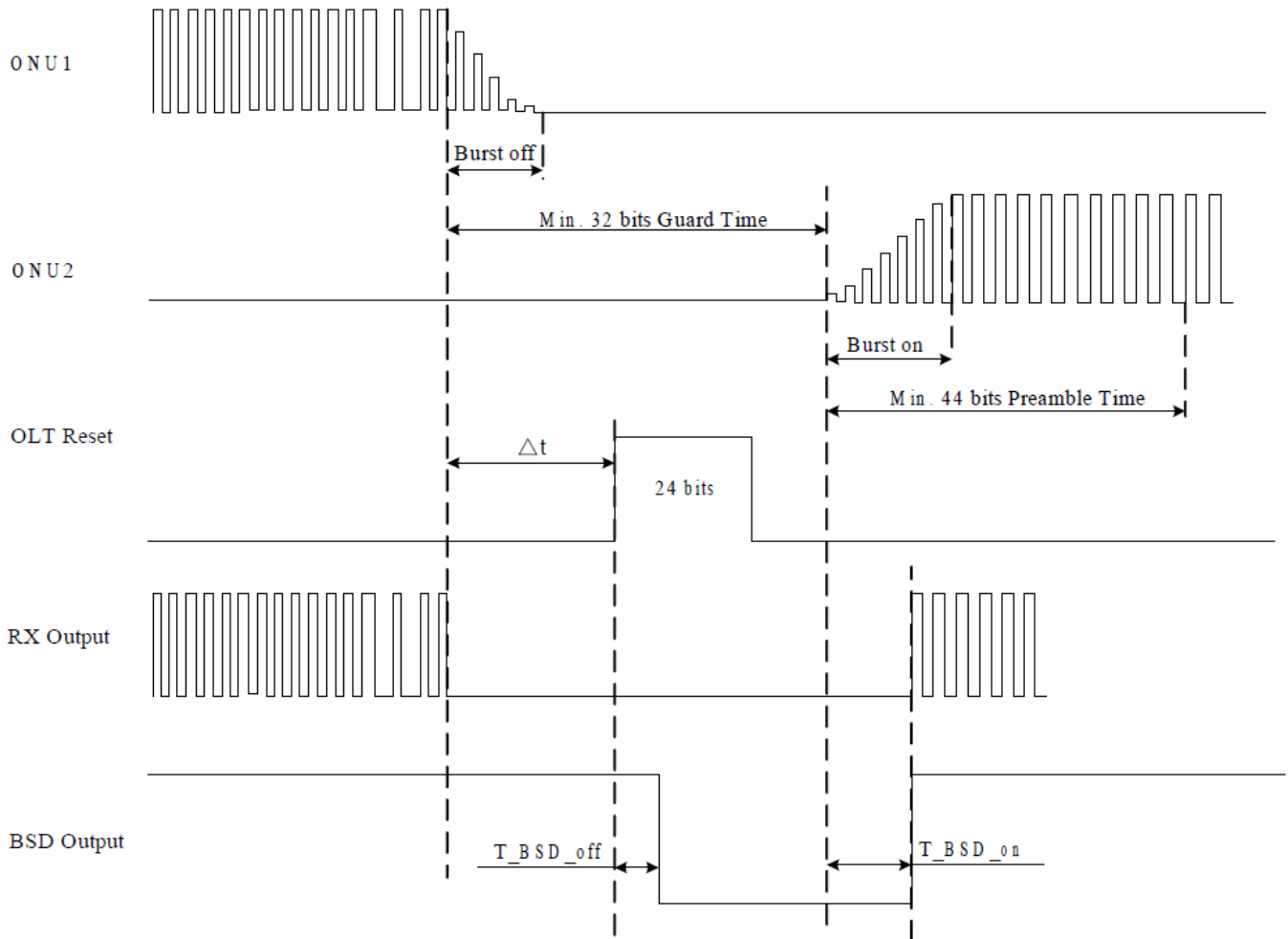

**Figure 2 Reset Timin**

## 7. Digital Diagnostic Memory Map

The transceivers provide serial ID memory contents and diagnostic information about the present operating conditions by the 2-wire serial interface (SCL, SDA).

The diagnostic information with internal calibration or external calibration all are implemented, including received power monitoring, transmitted power monitoring, bias current monitoring, supply voltage monitoring and temperature monitoring.

The digital diagnostic memory map specific data field defines as following.

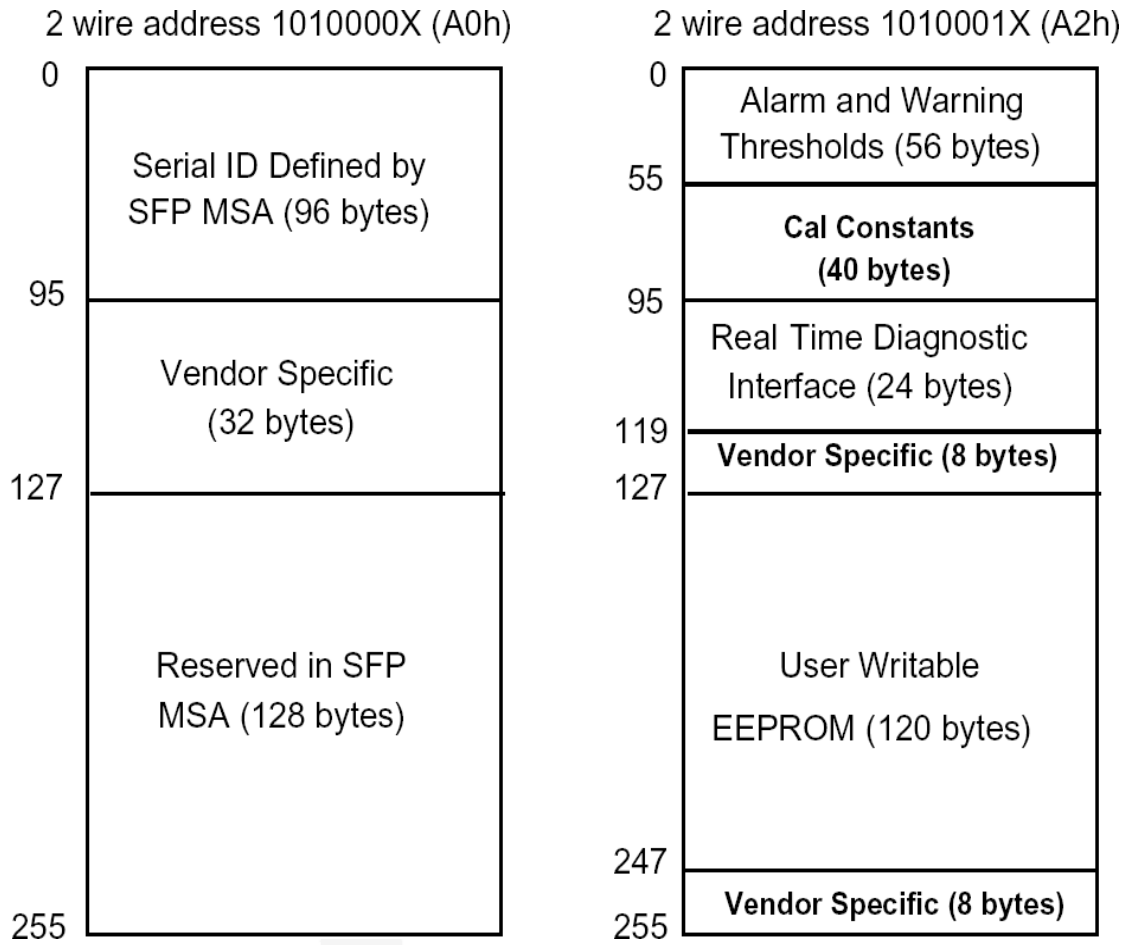

## 8. Pin Definitions

### Pin Diagram

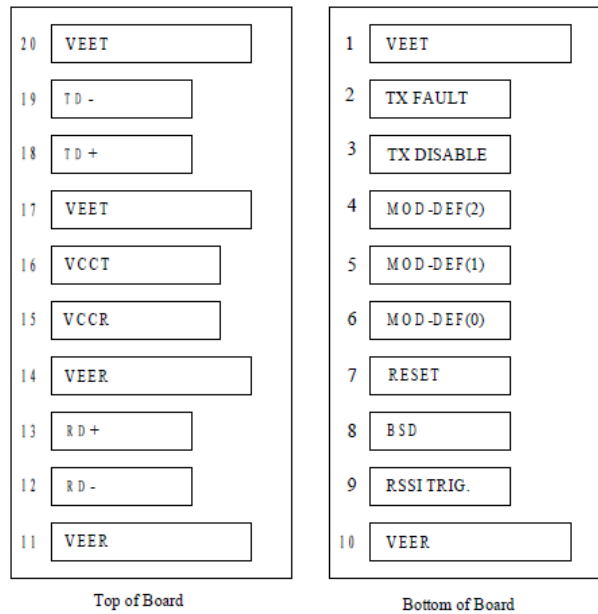

### Pin Descriptions

Pin	Signal Name	Description	Plug Seq.	Notes
1	VEET	Transmitter Ground	1	
2	TX FAULT	Transmitter Fault Indication	3	Note 1
3	TX DISABLE	Transmitter Disable	3	Note 2
4	MOD_DEF(2)	SDA Serial Data Signal	3	Note 3
5	MOD_DEF(1)	SCL Serial Clock Signal	3	Note 3
6	MOD_DEF(0)	TTL Low	3	Note 3
7	RESET	LVTTTL input. Assert "Reset" high at the end of previous burst,16 bits in duration	3	Note 4
8	BSD	Burst signal detect	3	Note 5
9	RSSI TRIG.	CMOS input. Assert high at the beginning of the monitored burst package,at least 300ns in duration	3	Note 6
10	VEER	Receiver ground	1	
11	VEER	Receiver ground	1	
12	RD-	Inv. Received Data Out	3	Note 7
13	RD+	Received Data Out	3	Note 7
14	VEER	Receiver ground	1	
15	VCCR	Receiver Power Supply	2	

16	VCCT	Transmitter Power Supply	2	
17	VEET	Transmitter Ground	1	
18	TD+	Transmit Data In	3	Note 8
19	TD-	Inv. Transmit Data In	3	Note 8
20	VEET	Transmitter Ground	1	

**Notes:**

Plug Seq.: Pin engagement sequence during hot plugging.

- 1) TX Fault is an open collector output, which should be pulled up with a 4.7k~10kΩ resistor on the host board to a voltage between 2.0V and Vcc+0.3V. Logic 0 indicates normal operation; Logic 1 indicates a laser fault of some kind. In the low state, the output will be pulled to less than 0.8V.
- 2) TX Disable is an input that is used to shut down the transmitter optical output. It is pulled up within the module with a 4.7k~10kΩ resistor. Its states are:
  - Low (0 to 0.8V): Transmitter on
  - (>0.8V, < 2.0V): Undefined
  - High (2.0 to 3.465V): Transmitter Disabled
  - Open: Transmitter Disabled
- 3) Mod-Def 0,1,2. These are the module definition pins. They should be pulled up with a 4.7k~10kΩ resistor on the host board. The pull-up voltage shall be VccT or VccR.
  - Mod-Def 0 is grounded by the module to indicate that the module is present
  - Mod-Def 1 is the clock line of two wire serial interface for serial ID
  - Mod-Def 2 is the data line of two wire serial interface for serial ID
- 4) RESET is a LVTTTL input. When the previous burst signal package is end, the host will give a “high” RESET to restore the state of LA. Internal pull-down 10K resistor to GND.
- 5) BSD can track the state of receiving burst signal. Logic 0 indicates loss of signal; Logic1 indicates receiving signal packages.
- 6) RSSI TRIG is a CMOS input. Assert high after 30ns delay time of the beginning of the monitored burst package,at least 300ns in duration.
- 7) RD-/+: These are the differential receiver outputs. They are internally DC-coupled 100 differential lines which should be terminated with 100Ω (differential) at the user SERDES.
- 8) TD-/+: These are the differential transmitter inputs. They are internally AC-coupled, differential lines with 100Ω differential termination inside the module.



## 9. Recommended Interface Circuit

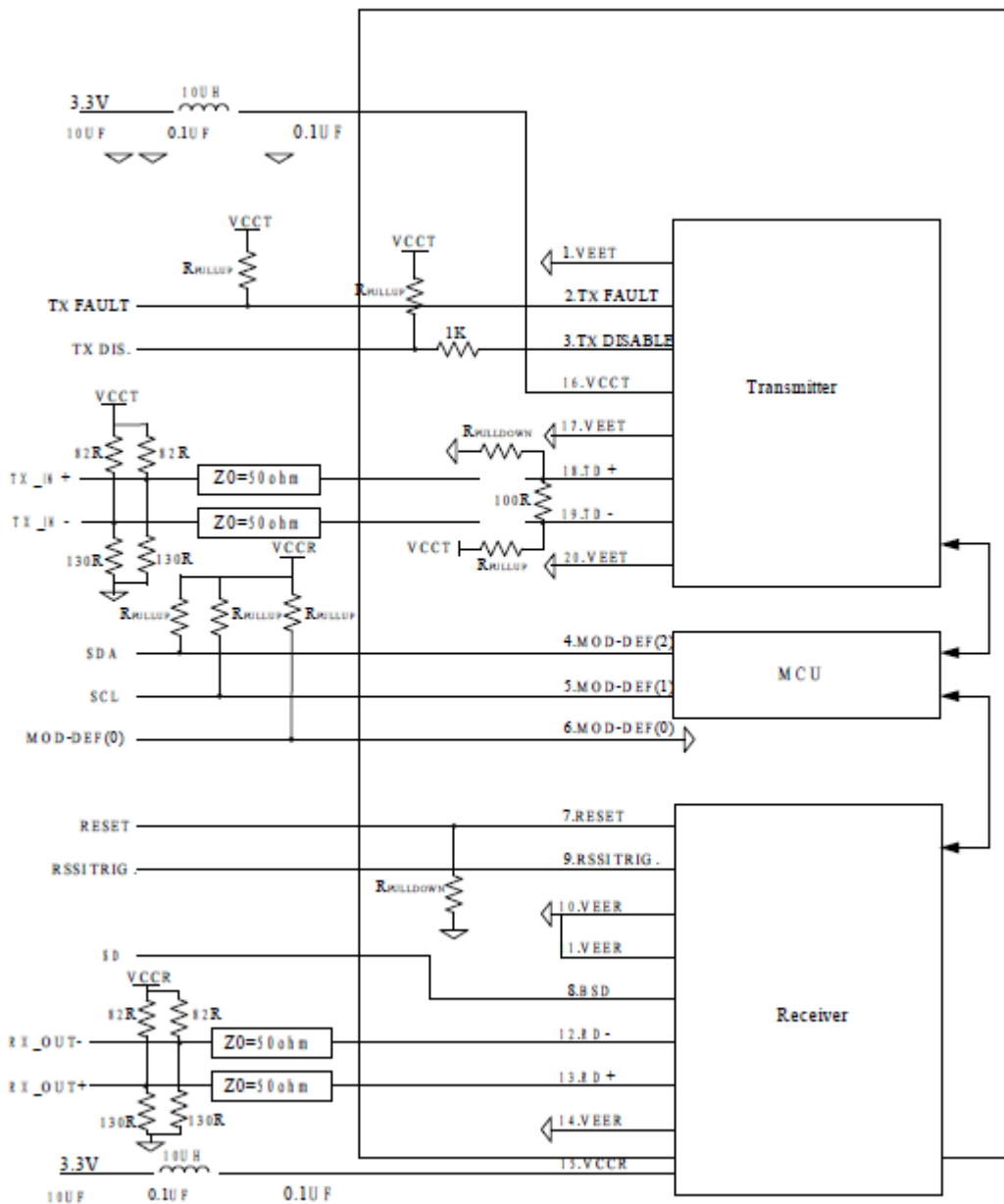

## 10. Mechanical Dimensions

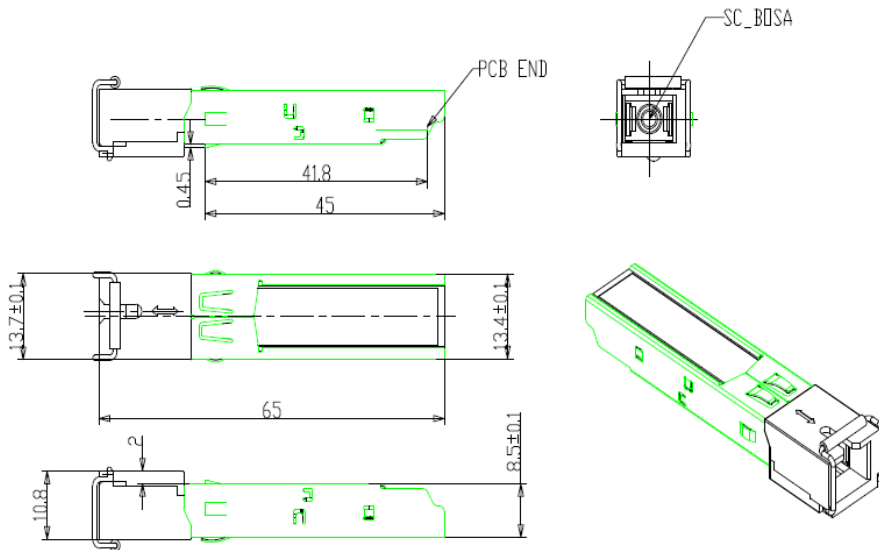

## 11. Ordering information

Part Number	Product Description
6C-GPON-OLT-7	GPON-OLT,1.25Gb/s,1490nm,SMF,20KM,DDM,SC connector, 0°C to +70°C