

6C-EPON-OLT++

6COM,EPON-OLT,1.25Gb/s,1490nm,SMF,20KM,DDM,SC connector, 0°C to +70°C

FEATURES

- ◆ Single fiber Bi-Directional transceiver with single mode SC receptacle
- ◆ 1490nm continuous-mode 1.25Gbps transmitter with DFB laser
- ◆ 1310nm burst-mode 1.25Gbps receiver with APD
- ◆ Complies with IEEE Std 802.3ah™ -2004 1000BASE-PX20
- ◆ Digital diagnostic interface compliant with SFF-8472 Rev 9.4 , Digital Diagnostic Monitoring (DDM) with external calibration
- ◆ 3.3V Single power supply
- ◆ LVPECL interface logic level for data input
- ◆ CML interface logic level for data output
- ◆ Differential line input/output impedance 100 ohm
- ◆ LVTTTL for burst signal input and signal detect output
- ◆ Complies with RoHS directive (2002/95/EC)
- ◆ Operating case temperature:
Standard: 0 to +70°C



APPLICATIONS

Gigabit Ethernet Passive Optical Network (EPON)

DESCRIPTION

6C-EPON-OLT++ Bi-Directional Transceiver is based on the IEEE 802.3ah 1000BASE PX-20 specification for bidirectional communications over a single fiber and incorporates a high performance 1310nm burst mode APD Receiver and 1490nm CW mode DFB transmitter.

1. Absolute Maximum Ratings

Parameter	Symbol	Min.	Max.	Units	Notes
Storage Temperature	Tst	-40	+85	°C	-
Operating Case Temperature	Tc	0	70	°C	-
Operating Humidity	RH	5	90	%	Non-condensing
Input Voltage	-	GND	Vcc	V	-
Power Supply Voltage	Vcc-Vee	0	3.6	V	-

2. Recommended Operating Conditions

Parameter	Standard	Symbol	Min	Typical	Max	Unit
Operating Case Temperature		Tc	0	-	+70	°C
Power Supply Voltage		Vcc	3.13	3.3	3.47	V
Power Supply Current		Icc	-	-	400	mA

3. Optical and Electrical Characteristics

Parameter	Symbol	Min	Typical	Max	Unit	Notes
Transmitter						
Tx Data Rate	RT	-	1.25	-	Gb/S	-
Centre Wavelength	λ_c	1480	1490	1510	nm	-
Spectral Width	$\Delta\lambda$	-	-	3	nm	-
Side Mode Suppression Ratio	SMSR	30	-	-	dB	-
Average Output Power	Pout	3.5	-	7	dBm	1
Extinction Ratio	ER	9	-	-	dB	-
Burst Enable Delay	Ton	-	-	32	ns	Fig.1
Burst Disable Delay	Toff	-	-	32	ns	Fig.1
Average Launch Power-OFF Transmitter	Poff			-41	dBm	
Optical Eye Diagram	Compliant with of IEEE 802.3ah (Fig. 60-6) transmitter eye mask definition					
Optical Rise/Fall Time (20%~80%)	tr/tf			260	ps	
Data Input Swing Differential	VIN	200		1600	mV	2
Input Differential Impedance	ZIN	90	100	110	Ω	
Burst	Disable	2.0		Vcc	V	
	Enable	0		0.8	V	
TX Fault	Fault	2.0		Vcc	V	
	Normal	0		0.8	V	
Receiver						
Rx Data Rate	RR	-	1.25	-	Gb/s	3
Centre Wavelength	λ_c	1260		1360	nm	
Receiver Sensitivity(BOL)	Sen			-30	dBm	3
Receiver Overload	Sat	-3			dBm	3
Receiver Reflectance				-12	dB	
Signal Detect De-Assert	SDD	-44			dBm	
Signal Detect Assert	SDA			-31	dBm	
Signal Detect Hysteresis	SDH	0.5		6	dB	

Output Differential Impedance		ZIN	90	100	110	Ω	
Data Output Swing Differential		Vout	400		1000	mV	
SD Output Voltage	High		2.0		Vcc	V	
	Low		0		0.8	V	

Notes:

1. The optical power is launched into SMF.
2. PECL input, internally DC-coupled and terminated.
3. Measured with a PRBS 2⁷-1 test pattern @1250Mbps, BER ≤1×10⁻¹².

4. Diagnostics

Parameter	Range	Unit	Accuracy	Calibration
Temperature	0 to 70	°C	±3°C	Internal / External
Voltage	3.0 to 3.6	V	±3%	Internal / External
Bias Current	0 to 100	mA	±10%	Internal / External
TX Power	0 to 4	dBm	±3dB	Internal / External
RX Power	-26 to -3	dBm	±3dB	Internal / External

5. Transmitter Burst Mode Timing Characteristics

Definition of Burst Enable Delay (T_{on}) and Burst Disable Delay (T_{off})

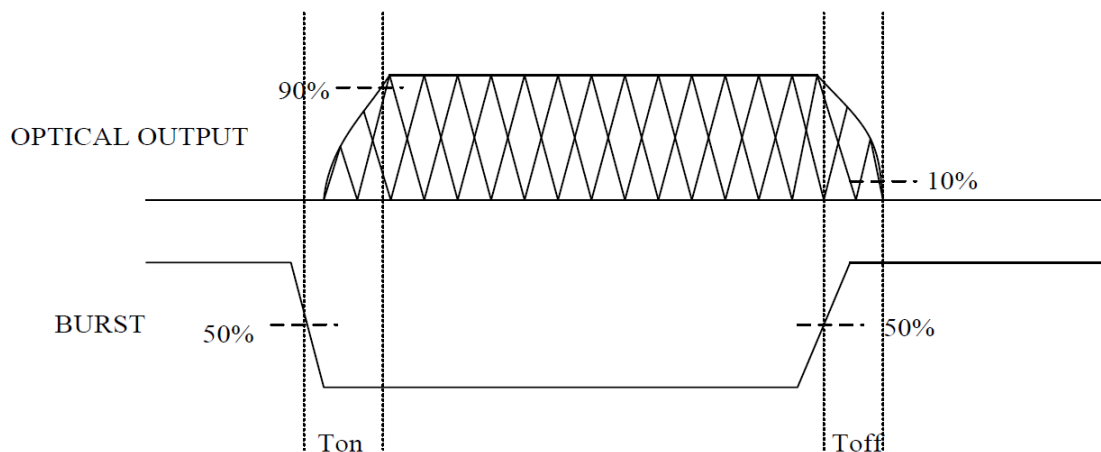

Fig.1

6. Digital Diagnostic Memory Map

The transceivers provide serial ID memory contents and diagnostic information about the present operating conditions by the 2-wire serial interface (SCL, SDA).

The diagnostic information with internal calibration or external calibration all are implemented, including received power monitoring, transmitted power monitoring, bias current monitoring, surpplly voltage monitoring and temperature monitoring.

The digital diagnostic memory map specific data field defines as following.

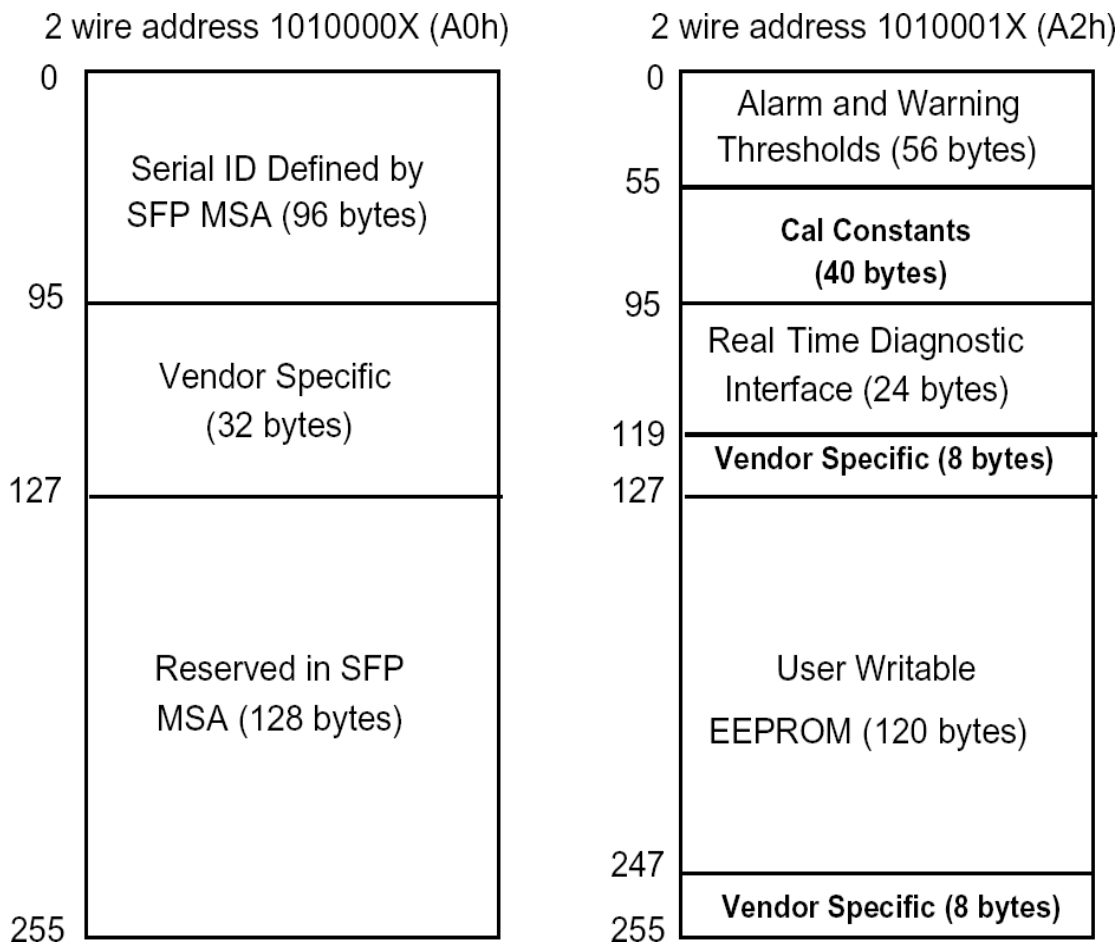

7. Pin Definitions

Pin Diagram

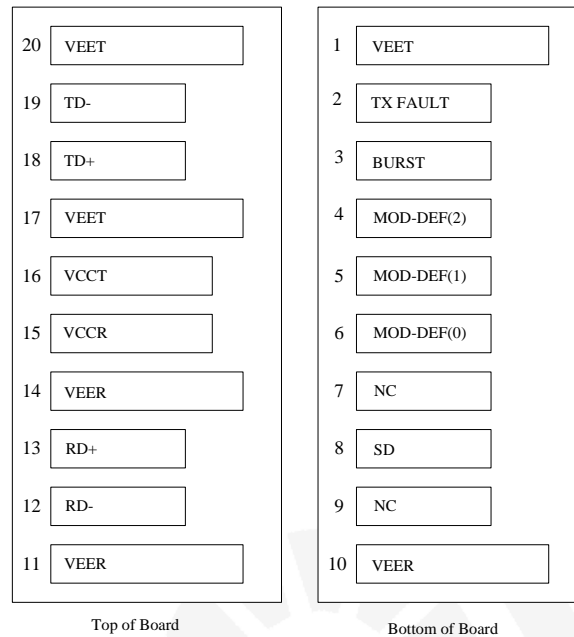

Pin	Signal Name	Description	Plug Seq.	Notes
1	VEET	Transmitter Ground	1	
2	TX FAULT	Transmitter Fault Indication	3	Note 1
3	BURST	Burst Single	3	Note 2
4	MOD_DEF(2)	SDA Serial Data Signal	3	Note 3
5	MOD_DEF(1)	SCL Serial Clock Signal	3	Note 3
6	MOD_DEF(0)	TTL Low	3	Note 3
7	-	-	3	
8	SD	Signal Detect Output	3	Note 4
9	-	-	3	
10	VEER	Receiver ground	1	
11	VEER	Receiver ground	1	
12	RD-	Inv. Received Data CML Output, internal AC Coupling	3	Note 5
13	RD+	Received Data CML Output, internal AC Coupling	3	Note 5
14	VEER	Receiver ground	1	
15	VCCR	Receiver Power Supply	2	
16	VCCT	Transmitter Power Supply	2	
17	VEET	Transmitter Ground	1	

18	TD+	Transmit Data LVPECL Input, Internal DC Coupling	3	Note 6
19	TD-	Inv. Transmit Data LVPECL Input, Internal DC Coupling	3	Note 6
20	VEET	Transmitter Ground	1	

Notes:

Plug Seq.: Pin engagement sequence during hot plugging.

- 1) TX Fault is an open collector output, which should be pulled up with a 4.7k~10kΩ resistor on the host board to a voltage between 2.0V and Vcc+0.3V. Logic 0 indicates normal operation; Logic 1 indicates a laser fault of some kind. In the low state, the output will be pulled to less than 0.8V.
- 2) BURST is a TTL input. When it is low, LD is on; when it is high, LD is off.
- 3) Mod-Def 0,1,2. These are the module definition pins. They should be pulled up with a 4.7k~10kΩ resistor on the host board. The pull-up voltage shall be VccT or VccR.
Mod-Def 0 is grounded by the module to indicate that the module is present
Mod-Def 1 is the clock line of two wire serial interface for serial ID
Mod-Def 2 is the data line of two wire serial interface for serial ID
- 4) SD is an open collector output, which should be pulled up with a 4.7k~10kΩ resistor. Pull up voltage between 2.0V and Vcc+0.3V. Logic 0 indicates loss of signal; Logic 1 indicates normal operation. In the low state, the output will be pulled to less than 0.8V.
- 5) RD-/+ : These are the differential receiver outputs. They are internally AC-coupled 100 differential lines which should be terminated with 100Ω (differential) at the user SERDES.
- 6) TD-/+ : These are the differential transmitter inputs. They are internally DC-coupled, differential lines with 100Ω differential termination inside the module.

8. Recommend Application Circuit

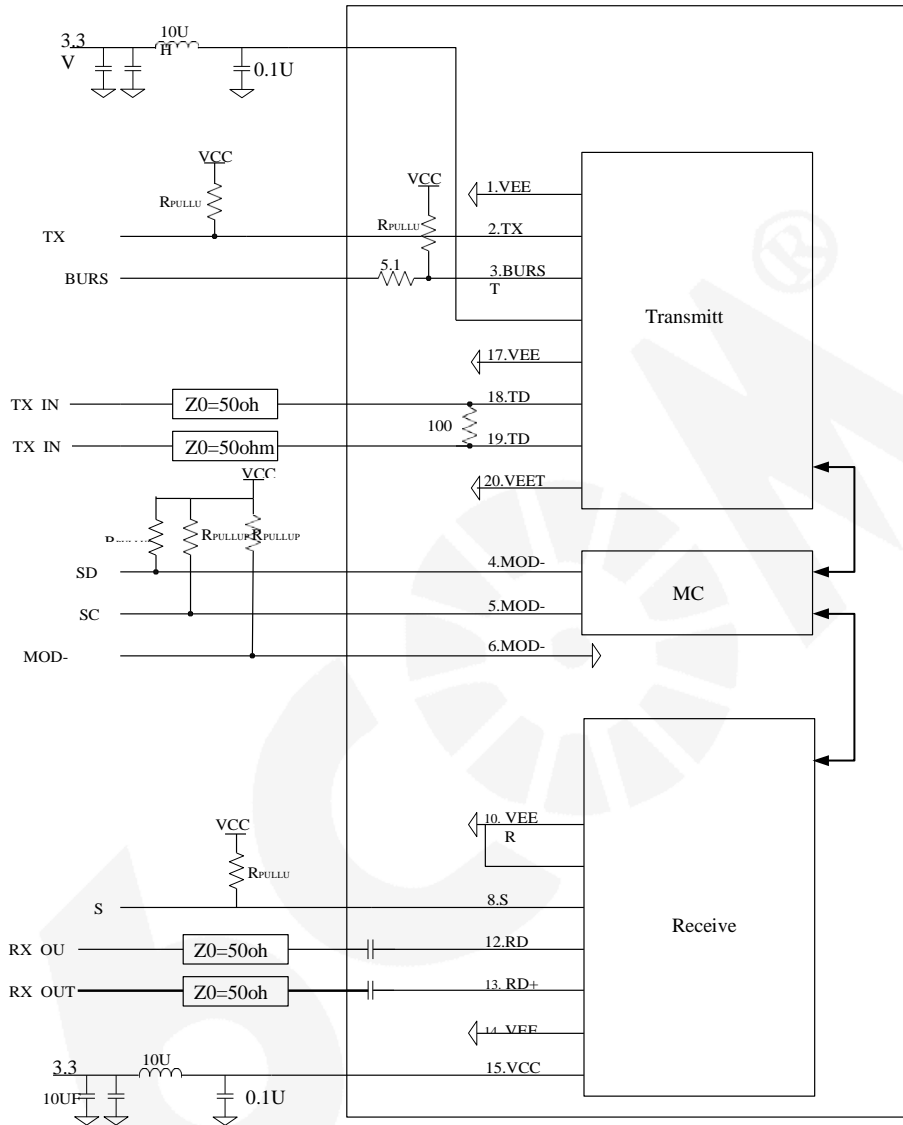

9. Mechanical Dimensions

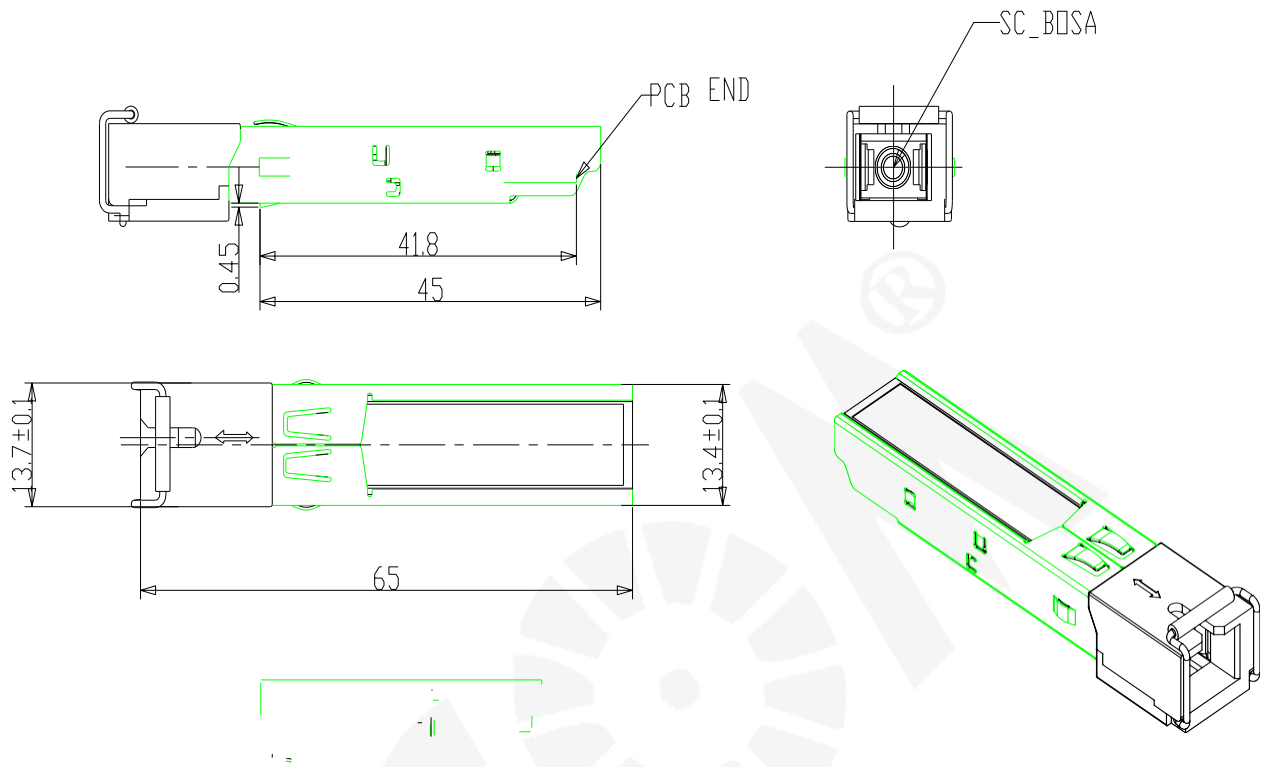

10. Ordering information

Part Number	Product Description
6C-EPON-OLT++	EPON-OLT, 1.25Gb/s, 1490nm, SMF, 20KM, DDM, SC connector, 0°C to +70°C