

DWDM-2.5G-80D-XX

6COM,DWDM SFP, 2.5Gb/s,1510-1610nm,SMF,80km,DDM,LC connector, 0°C to +70°C

FEATURES

- ◆ Wavelength selectable to C-band and L-band ITU-T grid wavelengths
- ◆ Suitable for use in 100GHz channel spacing DWDM systems
- ◆ DWDM SFP MSA Compliant
- ◆ Up to 2.5 Gb/s data rate
- ◆ Cold Start up Wavelength Compliance
- ◆ Low Power Dissipation <1.3W Maximum
- ◆ -5°C to 70°C Operating Case Temperature
- ◆ Diagnostic Performance Monitoring of module temperature, supply
- ◆ Voltages, laser bias current, transmit optical power, receive optical power,
- ◆ Laser temperature and TEC current
- ◆ Extended link budget with APD receiver technology
- ◆ RoHS compliant and lead free



APPLICATIONS

- ◆ SFP Transceivers for DWDM SONET/ SDH
- ◆ Ethernet IEEE 802.3ae
- ◆ Fiber Channel

1. Description

6COM DWDM SFP Transceiver exhibits excellent wavelength stability, supporting operation at 100 GHz channel, cost effective module. It is designed for DWDM SONET/ SDH, Gigabit Ethernet and Fiber- Channel applications.

The transceiver consists of two sections: The transmitter section incorporates a colded DFB laser. And the receiver section consists of an APD photodiode integrated with a TIA. All modules satisfy class I laser safety requirements. 6COM DWDM SFP transceiver provides an enhanced monitoring interface, which allows real-time access to device operating parameters such as transceiver temperature, laser bias current, transmitted optical power, received optical power and transceiver supply voltage, laser temperature and TEC current.

2. Absolute Maximum Ratings

Parameter	Symbol	Min	Max	Unit
Supply Voltage	Vcc	-0.3	4.0	V
Storage Temperature	Tst	-40	85	°C
Data AC Voltage	TX+-AC	-	2.4	Vpp
Data DC Voltage	TX+-DC	-0.5	2.5	V
Optical Input Received Power	PIN	-	+5	dBm

3. Operating Conditions

Parameter	Symbol	Min	Typical	Max	Unit
Supply Voltage	Vcc	3.13	3.3	3.47	V
Operating Case temperature	Tca	-5	-	70	°C
Total Current	Icc	-	-	380	mA
Module Power Dissipation	Pm	-	0.8	1.3	W

4. Transmitter Specifications – Optical

Parameter	Symbol	Min	Typical	Max	Unit
Data Rate Multirate	Mra	155	2488	2667	Mbps
Center Wavelength (SOL) Δ	c	c -25	c	c +25	pm
Center Wavelength (EOL) \blacktriangle	c	c -100	c	c+100	pm
Optical Transmit Power	Po	0	2	5	dBm
Optical Transmit Power (disabled)	PTX_DISABLE	-	-	-40	dBm
Extinction Ratio	ER	8.2		-	dB
Channel Spacing	Δf	-	100	-	GHz
Jitter Generation	TJP-P	-	-	70	mUI
Spectral Width (-20dB)	DI20	-	0.1	0.3	nm
Side Mode Suppression	SMSR	30	-	-	dB
Eye Mask	Compliant with Bell core GR-253-CORE & ITU G.957 for SONET/SDH and with IEEE 802.3ae for Ethernet and Fibre Channel				

Δ Laser- Start of Life

\blacktriangle Laser End of life

5. Transmitter Specifications – Electrical

Parameter	Symbol	Min	Typical	Max	Unit
Supply Voltage	VccTX	3.13	3.3	3.47	V
PECL/CML Input	VtxDIFF	500	-	1600	mV
Input Rise/Fall	TR / TF	-	-	160	ps
TX-Fault Fault	Vf	2	-	Vcc	V
TX-Fault Normal	Vn	Vee	-	Vee+0.5	V
TX_DISABLE (asserted)	VDH	2	-	Vcc	V
TX_DISABLE	VDL	Vee	-	Vee+0.8	V

6. APD Receiver Specifications – Optical

Parameter	Symbol	Min	Typical	Max	Unit
Receiver Sensitivity(OC24)	Rsens-1	-	-30	-28	dBm
Receiver Sensitivity (OSNR = 20dB)	Rsens-2	-	-	-24	dBm
Maximum Input Power	RX-overload	-	-	-7	dBm
Input Operating Wavelength	λ	1528	-	1564	nm
Reflectance	Rrx	-	-	-27	dB
Loss of Signal Asserted		-40	-	-	dBm
LOS De-Asserted		-	-	-34	dBm
LOS Hysteresis		0.5	-	-	dB

7. APD Receiver Specifications – Electrical

Parameter	Symbol	Min	Typical	Max	Unit
Supply Voltage	VccRX	3.13	3.3	3.47	V
Differential Output Swing	Vout P-P	370	-	2000	mV
Rise/Fall Time	Tr / Tf	-	-	175	ps
Loss of Signal –Asserted	VOH	2	-	Vcc	V
Loss of Signal –Negated	VOL	Vee	-	Vee+0.5	V

8. Low Speed Electrical Signal Timings

Parameter	Symbol	Min	Typical	Max	Unit
TX Disable Negate Time	t-on	-	-	20	ms
TX Disable Assert Time	t-off	-	-	20	ms
Time to initialize, including reset of TX_FAULT	t_init	-	-	300	ms
Start-up Time	t_startup	-	-	90	s
TX_FAULT/INT Assert Time	t_fault	-	-	50	ms
TX_DISABLE to Reset	t_reset	10	-	-	ms
LOS Assert Time	t_los_on	-	-	100	us
LOS Negate Time	t_los_off	-	-	100	us
Serial ID Clock Rate	f_serial_clock	-	-	100	kHz



9. C-band λ_c Wavelength Guide

ITU Channel Product Code	Frequency(THz)	Wavelength	ITU Channel Product Code	Frequency(THz)	Wavelength
17	191.7	1563.86	40	194.0	1545.32
18	191.8	1563.05	41	194.1	1544.53
19	191.9	1562.23	42	194.2	1543.73
20	192.0	1561.42	43	194.3	1542.94
21	192.1	1560.61	44	194.4	1542.14
22	192.2	1559.79	45	194.5	1541.35
23	192.3	1558.98	46	194.6	1540.56
24	192.4	1558.17	47	194.7	1539.77
25	192.5	1557.36	48	194.8	1538.98
26	192.6	1556.55	49	194.9	1538.19
27	192.7	1555.75	50	195.0	1537.40
28	192.8	1554.94	51	195.1	1536.61
29	192.9	1554.13	52	195.2	1535.82
30	193.0	1553.33	53	195.3	1535.04
31	193.1	1552.52	54	195.4	1534.25
32	193.2	1551.72	55	195.5	1533.47
33	193.3	1550.92	56	195.6	1532.68
34	193.4	1550.12	57	195.7	1531.90
35	193.5	1549.32	58	195.8	1531.12
36	193.6	1548.51	59	195.9	1530.33
37	193.7	1547.72	60	196.0	1529.55
38	193.8	1546.92	61	196.1	1528.77
39	193.9	1546.12			

10. L-band λ_c Wavelength Guide

ITU Channel Product Code	Frequency(THz)	Wavelength	ITU Channel Product Code	Frequency(THz)	Wavelength
62	186.2	1610.06	90	189.0	1586.20
63	186.3	1609.19	91	189.1	1585.36
64	186.4	1608.33	92	189.2	1584.53
65	186.5	1607.47	93	189.3	1583.69
66	186.6	1606.61	94	189.4	1582.85
67	186.7	1605.74	95	189.5	1582.02
68	186.8	1604.88	96	189.6	1581.18



69	186.9	1604.03	97	189.7	1580.35
70	187.0	1603.17	98	189.8	1579.52
71	187.1	1602.31	99	189.9	1578.69
72	187.2	1601.46	00	190.0	1577.86
73	187.3	1600.60	01	190.1	1577.03
74	187.3	1599.75	02	190.2	1576.20
75	187.5	1598.89	03	190.3	1575.37
76	187.6	1598.04	04	190.4	1574.54
77	187.7	1597.19	05	190.5	1573.71
78	187.8	1596.34	06	190.6	1572.89
79	187.9	1595.49	07	190.7	1572.06
80	188.0	1594.64	08	190.8	1571.24
81	188.1	1593.79	09	190.9	1570.42
82	188.2	1592.95	10	191.0	1569.59
83	188.3	1592.10	11	191.1	1568.77
84	188.4	1591.26	12	192.2	1567.95
85	188.5	1590.41	13	192.3	1567.13
86	188.6	1589.57	14	191.4	1566.31
87	188.7	1588.73	15	191.5	1565.50
88	188.8	1587.88	16	191.6	1564.68
89	188.9	1587.04			

11. Table 1: EEPROM Serial ID Memory Contents (A0h):

Data Address	Field Size (Bytes)	Value	Name of Field	Description and Contents
Base ID Fields				
0	1	0Bh	Identifier	Type of Serial transceiver
1	1	24h	Ext. Identifier	Extended identifier of type serial transceiver
2	1	07h	Connector	Code of optical connector type
3-10	8	00h,0Ch,44h,00h,80h,10h,01h,00h	Transceiver	Code for electronic compatibility or optical compatibility
11	1	03h	Encoding	Code for serial encoding algorithm
12	1	19h	BR,Nominal	Nominal baud rate, unit of 100Mbps
13-14	2	78h(120km)	Length (9μm) – km	Link length supported for 9/125μm fiber, units in km
15	1	46h	Max Temp	Maximum operating case temperature in °C
16	1	FBh	Min Temp	Minimum operating case temperature in °C
17	1	5Fh	Max Supply Current	Maximum supply current in units of 4mA
18	1	00h	Reserved	-

19	1	41h	Channel spacing and number	Channel spacing compatibility and number and tuning of ITU channels supported
20-35	16	Module dependent	Vendor Name	SFP vendor name: "6COM" (ASCII)
36	1	02h	Reserved	Optional DWDM features
37-39	3	-	Vendor OUI	SFP transceiver vendor IEEE company ID
40-55	16	DWDM-XX-XX-XX	Vendor PN	Part number provided by SFP transceiver vendor (ASCII)
56-59	4	Module dependent	Vendor rev	Revision level for part number provided by vendor (ASCII)
60-61	2	Module dependent	wavelength	Laser wavelength (in nm)
62	1	Module dependent	wavelength	Laser wavelength (fractional part in units of 10pm)
63	1	Module dependent	CC_BASE	Check sum of bytes 0 - 62
Extended ID Fields				
64-65	2	1Ah	Option	Indicates which optical SFP signals are implemented
66	1	00h	BR, max	Upper bit rate margin, units of %
67	1	00h	BR, min	Lower bit rate margin, units of %
68-83	16	Module dependent	Vendor SN	Serial number (ASCII)
84-91	8	Module dependent	Date code	Year(2 bytes), Month(2 bytes), Day (2 bytes)
92	1	68h	Diagnostic type	Indicates the type of diagnostics implemented in Monitoring Type the transceiver
93	1	F0h	Enhanced option	Indicates which optional enhanced features Options are implemented
94	1	01h	SFF-8472	"01" Diagnostics(SFF-8472 Rev 9.3)
95	1	Module dependent	CC_EX	Check sum of bytes 64 - 94
Vendor Specific ID fields				
96-127	32	-	Vendor Specific	Vendor Specific EEPROM (Vendor specific data; Specific read only)
128-255	128	-	Reserved	Reserved for future use

12. Table 2: Serial ID Memory Contents: (A2H)

Address	# Bytes	Name	Description
00-55	56	Alarm and Warning Levels	Temp/ Vcc/ Bias Current /TX Power/ RX Power/ LD Temp/ TEC Current, High/Low Alarm and Warning Levels
56-94	39		Not used in DWDM devices. All Bytes Set to 0.
95	1	Checksum	Low order 8 bits of the sum of bytes 0-94
96-109	8	A/D Values	A/D binary values of the following enhanced diagnostics(Real-time): module temperature, supply voltage, laser bias current, transmit optical power, receive optical power, laser temperature and TEC current. These values are Internally calibrated absolute measurements. All diagnostic parameters implemented in these address locations have a corresponding high and low, alarm

			and warning thresholds assigned in address locations 00-55.
110	1	Soft Control Signals	Soft control signals monitored over the 2-wire access port. can updated real-time status of the following control signals: TX_FAULT, TX_DISABLE, Rate Select, and LOS.
111	1	Reserved	Reserved
112-117	5	Alarm/Warning Flags	Optional Alarm and Warning Flag and Mask Bits Corresponding to levels detailed in addresses 00-39 above.
118-119	2	Warning Mask	Masking bits corresponding to Warning bits of bytes 116 and 117 respectively
120-126	8	Vendor Specific	Vendor specific data
127	1	Table Select	The byte value defines the Table location for subsequent reads and writes to bytes locations 128-255
128-247	120	User EEPROM	User writable EEPROM
248-255	8	Vendor Specific	Vendor specific control functions

13. Table 3: Digital Diagnostic Monitoring A/D Accuracy

Parameter	Range	Accuracy	Unit
Temperature	-40~100	± 3	°C
Voltage	0~Vcc	0.1	V
Bias Current	0~120	5	mA
TX Power	0~5	± 2	dBm
RX Power	-32~-8	± 2	dBm
TEC Current	-1200~1200	± 65	mA
LD Temperature	20~70	± 0.25	°C

14. Pin Definitions

Pin Number	Name	Function	Ref.
1	VEET	Transmitter Ground	
2	TX_FAULT/INT	Transmitter Fault	1
3	TX_DISABLE	Transmitter Disable	2
4	MOD-DEF(2)	Module Definition 2	3
5	MOD-DEF(1)	Module Definition 1	3
6	MOD-DEF(0)	Module Definition 0	3
7	Tone in	Rate Select -Not Implemented	
8	LOS	Loss of Signal	4
9	VEER	Receiver Ground	
10	VEER	Receiver Ground	
11	VEER	Receiver Ground	
12	RD-	Inverted Received	
13	RD+	Received Data	
14	VEER	Receiver Ground	
15	VCCR	Receiver Power	
16	VCCT	Transmitter Power	
17	VEET	Transmitter Ground	
18	TD+	Transmit Data	

19	TD-	Inverted Transmit	
20	VEET	Transmitter Ground	

Notes:

1. TX Fault is an open collector/drain output, which should be pulled up with a 4.7K – 10K. resistor on the host board. Pull up voltage between 2.0V and VccT, R+0.3V. When high, output indicates a laser fault of some kind. Low indicates normal operation. In the low state, the output will be pulled to < 0.8V.
2. TX disable is an input that is used to shut down the transmitter optical output. It is pulled up within the module with a 4.7 – 10 K. resistor.
3. These are the module definition pins. They should be pulled up with a 4.7K – 10K. resistor on the host board. The pull-up voltage shall be VccT or VccR (see Section IV for further details).
4. LOS (Loss of Signal) is an open collector/drain output, which should be pulled up with a 4.7K – 10K. resistor. Pull up voltage between 2.0V and VccT, R+0.3V. When high, this output indicates the received optical power is below the worst-case receiver sensitivity (as defined by the standard in use). Low indicates normal operation. In the low state, the output will be pulled to < 0.8V.

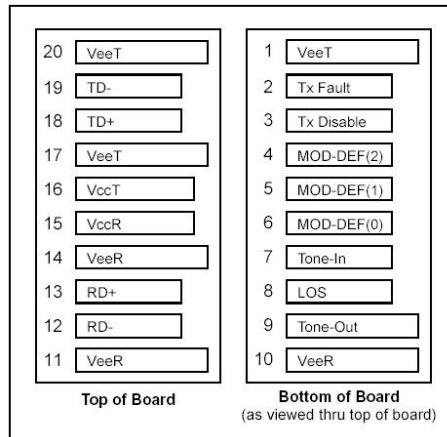

Figure1.Electrical Pin-out Details

15. Recommended Interface Circuit

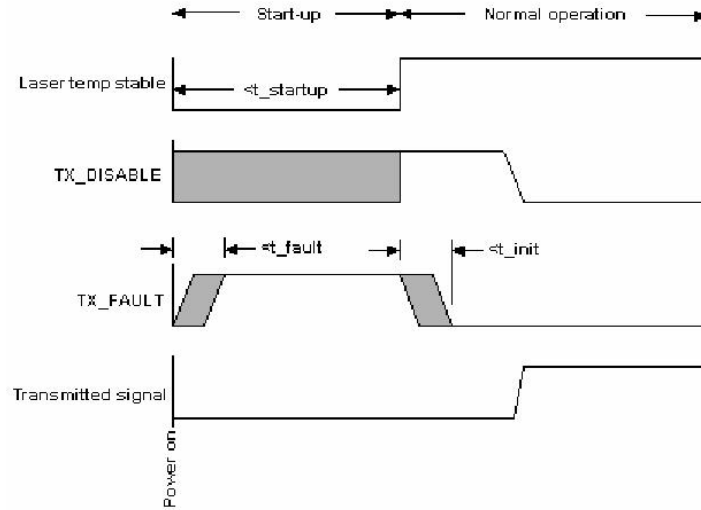

Figure2. Power-on initialisation of DWDM SFP transceiver

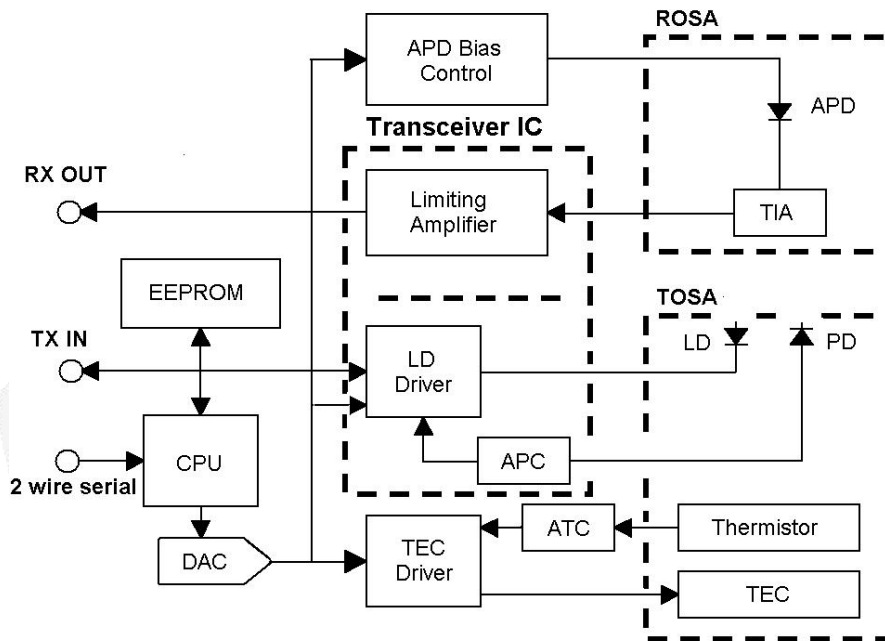

Figure3. Block Diagram of DWDM-SFP.

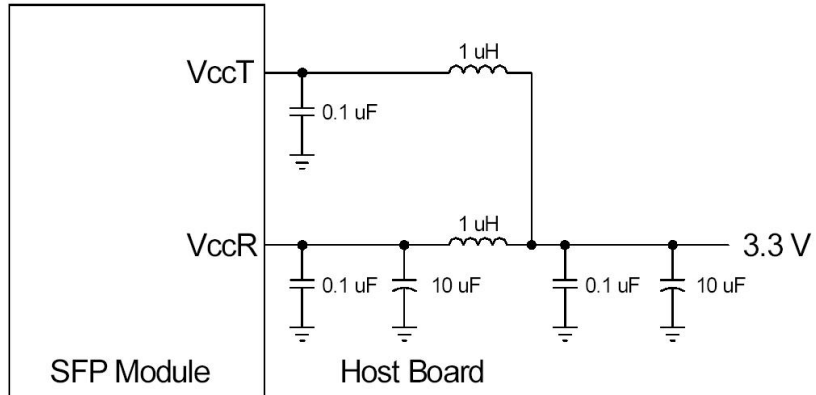

Figure4. Recommended Host Board Supply Filtering Network

16. Mechanical Dimensions

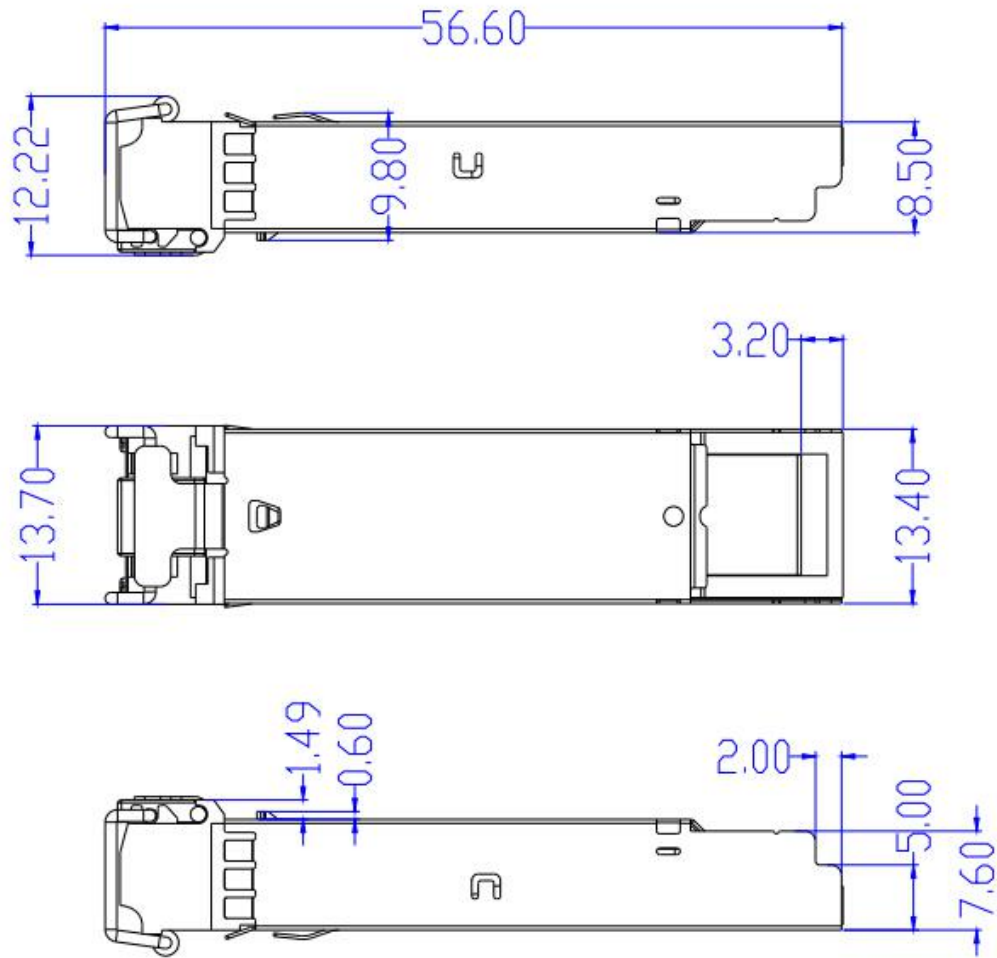

Figure5. Mechanical Dimensions

17. Ordering information

Part Number	Product Description
DWDM-2.5G-80D-XX	DWDM SFP, 2.5Gb/s,1510-1610nm,SMF,80km,DDM,LC connector, 0°C to +70°C
XX=17~61 (ITU Channel C-band) 62~16(ITU Channel L-band)	